



**General Motors Corporation
Legal Staff**

Facsimile
(313) 974-1260

Telephone
(313) 974-1572

SEP 09 1998

The Honorable Philip R. Recht
Deputy Administrator
NATIONAL HIGHWAY TRAFFIC
SAFETY ADMINISTRATION
400 Seventh Street, S.W., Room 5220
Washington, DC 20590

Dear Mr. Recht:

Re: **Settlement Agreement**
Section B. Fire Safety Research

Enclosed is a report prepared by the National Institute of Standards and Technology entitled "Burning Behavior of Selected Automotive Parts from a Minivan" that relates to Project B.10 (Study of Flammability of Materials).

Yours truly,

David A. Collins
Attorney

Enclosure

NISTIR 6143

Burning Behavior of Selected Automotive Parts from a Minivan

Thomas J. Ohlemiller
John R. Shields

Building and Fire Research Laboratory
Gaithersburg, Maryland 20899

NIST

United States Department of Commerce
Technology Administration
National Institute of Standards and Technology

NISTIR 6143

Burning Behavior of Selected Automotive Parts from a Minivan

Thomas J. Ohlemiller
John R. Shields

August, 1998
Building and Fire Research Laboratory
National Institute of Standards and Technology
Gaithersburg, MD 20899



U.S. Department of Commerce
William M. Daley, *Secretary*
Technology Administration
Gary Bachula, *Acting Under Secretary for Technology*
National Institute of Standards and Technology
Raymond G. Kammer, *Director*

NOTE

This report describes results from a Cooperative Research and Development Agreement between the National Institute of Standards and Technology and General Motors Corporation that addresses issues of post-crash automobile fire safety. This report was financed by General Motors pursuant to an agreement between General Motors and the United States Department of Transportation.

The National Institute of Standards and Technology (NIST) is applying its expertise in fire science to this program because of the potentially high impact of this program on vehicle safety in the United States. As a matter of policy, NIST does not test commercial products, especially without the consent of the manufacturers of those products. The National Highway Traffic Safety Administration and General Motors have selected the vehicles to be crash tested and the procedures for those tests. These exploratory tests are only meant to produce a variety of types of vehicle damage that might occur. Not all crash conditions were studied, and the repeatability of the tests cannot be determined since in most cases replicate tests were not conducted due to budgetary constraints. Thus, the results of the tests may facilitate identification of opportunities for improvements in vehicle fire safety, but cannot by themselves be extrapolated to the full fleet of vehicles and all crash conditions. In analyzing the data from these tests, certain vehicles, equipment, instruments or materials are identified in this paper in order to specify the experimental procedure adequately. In no case does such identification imply recommendation or endorsement by the National Institute of Standards and Technology, nor does it imply that the fire safety of a particular vehicle is superior or inferior to any other.

Table of Contents

1) Introduction	-1-
2) Factors Influencing the Burning Behavior of Thermoplastic Objects	-3-
External Factors	-4-
Internal Factors	-5-
3) Experimental Details	-7-
Test Objects	-7-
Flow Calorimeters	-8-
Ignition Conditions and Burning Configuration	-10-
Instrument Panel Test Configuration	-12-
4) Test Results	-13-
Battery	-13-
Air Intake Resonator	-18-
Headlamp Assembly	-19-
Brake Master Cylinder	-20-
Wiper Tray	-21-
Hood Liner	-24-
Rear Wheel Well Liner	-26-
Fuel Tank	-26-
Front Fender Sound Insulation	-28-
Instrument Panel Assembly	-28-
Front Passenger's Seat	-30-
Passenger Compartment Headliner	-31-
5) Discussion	-33-
6) Next Directions	-36-
7) References	-37-
8) Acknowledgment	-37-

Burning Behavior of Selected Automotive Parts From a Minivan

T. J. Ohlemiller and J. R. Shields

Abstract

Selected functional parts from a minivan were subjected to a gas flame ignition source and burned in a manner that allowed measurement of the resulting total heat release rate, mass loss and heat fluxes to the surroundings. This study was undertaken to: (1) assess a possible means for determining the flammability characteristics of automotive components, (2) obtain data on the range of flammability behavior exhibited by such components and the physical processes underlying that behavior, and (3) obtain insights into the fire behavior seen in related full-scale vehicle fires. For most of the vehicle components examined in this study, a significant aspect of the burn behavior was the development of a polymer melt pool fire below the part. A battery was burned in three different ways which impacted the rate of development of this pool fire and revealed a strong influence on the fire intensity. Other parts exhibited a wide variety of behavior influenced not only by their constituent polymer resins but also by their shapes, sizes and internal structures.

1) Introduction

This is the first report of results from Project B.10, "Study of Flammability of Materials," which is being performed as part of a Cooperative Research and Development Agreement (CRADA) between General Motors Corporation and NIST. It comprises one aspect of research engendered by an agreement between General Motors and the United States Department of Transportation.

Research under this Project will examine the flammability characteristics of automotive engine compartment fluids and solid materials from both the vehicle exterior and interior. Efforts will be made to identify or devise cost-effective, less flammable substitutes (with acceptable physical properties) for selected materials.

The present study complements related work (Project B.3) in which a limited number of vehicles selected by General Motors, in consultation with the National Highway Transportation Safety Administration (NHTSA), are being subjected to controlled crash tests; NIST, as part of its CRADA with GM, is participating in subsequent fire initiation/propagation tests on these crashed vehicles. The crash tests involve both rear and frontal impacts; thus the fire tests involve both

under-hood fires and gasoline pool fires under the vehicle. The principal concern in these fire tests is the manner and rate at which such fires grow and spread into the passenger compartment.

While such fires may be initiated by a variety of means, they grow and spread on the various combustible fluids and solid organic components that are integral parts of modern vehicles. Polymeric materials, in particular, which are the primary focus in this report, comprised some 100 kg of the typical vehicle in 1993 [Ref 1].¹ They offer weight savings and numerous other engineering advantages and thus the trend in usage is steadily upward.

Materials used in the passenger compartment are subject to Federal Motor Vehicle Safety Standard No. 302, Flammability of Interior Materials. The requirements of this test apply to all materials within 1.3 cm (1/2 in) of the occupant compartment air space. When subjected to a small Bunsen burner flame for 15 s, the materials must not allow flame spread on the horizontal surface of the test specimen to exceed a rate of 1.7 mm/s. This is a modest requirement that protects against minor threats such as a dropped match but does not assure good flammability behavior if the material is subjected to the more intense exposure conditions occurring in a vehicle fire. There are currently no nationally mandated flammability performance levels for the polymeric materials used elsewhere in motor vehicles.

Flammability behavior is the result of a complex set of factors; some of these are dictated by the material composition, others by the conditions of exposure. For a pure polymer, this behavior begins with the ability of its chemical bonds to resist heat-induced breakage. When a plastic object burns, it does so because heat from the flames (or elsewhere) is, in part, being transferred into the condensed phase and breaking off molecular fragments which oxidize in the gas phase to sustain the flames. Thus the thermal stability of a polymer is one significant measure of its flammability. A highly thermally stable polymer is more effectively able to reject the heat input from an adjacent flame because the high surface temperature it achieves before degrading to volatile fragments allows it to re-radiate more of that heat to the surroundings. On the other hand, the conditions of exposure could be such that the surroundings are not passive receivers of heat; they may themselves be hot and capable of radiating heat to the polymer surface. This heat tends to counter the surface radiation loss from the polymer and enhance its flammability because it helps sustain the high temperatures which induce thermal degradation. For a thermoplastic, the situation is more complex. Such materials melt and drip during flame exposure so that gravity causes a portion of the fuel to be transferred to some other surface.² Often the dripping material

¹There are potential circumstances in post-crash, rear-end fuel fed fires where burning gasoline exterior to the vehicle can be the primary threat to the passenger compartment, rendering any polymeric materials in the fire path secondary in importance. This occurs if a broken window or other crash-induced opening admits a substantial amount of the fire plume from the burning gasoline.

²Lightly cross-linked thermoset polymers can exhibit the same type of behavior if their thermal degradation results in a fluid "melt".

is flaming. Thus a pool fire tends to build up on the surface which captures the polymer melt. If this surface is sufficiently close to the original polymer or if the pool fire grows sufficiently, its flames will provide supplemental heating to the original polymer, enhancing its burning. Furthermore, for any polymer, the response to a heat input will depend on the thickness of the material and its shape; this makes the detailed shape of the part in which the polymer is actually used pertinent to a flammability assessment.

With these ideas as background, it is apparent that one can pursue improved flammability behavior at several levels. The thermal stability and other relevant thermophysical properties of existing and candidate replacement polymers can be assessed by thermal analysis techniques, including thermogravimetry and differential scanning calorimetry; General Motors is pursuing this aspect in their part of this project. The ignitability and burning behavior of simple slab-like shapes can be assessed in detail in flow calorimetry devices; Factory Mutual Research Corporation is pursuing this aspect of the project. Finally, the burning behavior of actual vehicle parts can be assessed in larger scale flow calorimetry devices. NIST is pursuing this last aspect, namely, the behavior of complex vehicle parts in actual functional form; this means that there may be several types of polymers and inorganic materials present. Eventually it is hoped that simpler, small-scale tests on component materials will provide a means for assessing the likely fire contribution from a complex, functional part of a vehicle.

It should be noted that financial constraints dictate that only a limited set of components from any vehicle can be tested. The particular sets of components selected for a given vehicle type are the result (in part) of engineering judgement (based mainly on mass and placement) as to their likely involvement in a particular type of fire scenario. In this case certain of the components examined here appeared to be participants in two full-scale fire tests of the minivan from which they come. Those full-scale tests represented only two scenarios among a myriad of possibilities. Thus it should not be inferred that the components chosen here are the only ones at risk with respect to fire, nor should it be inferred that only these components may benefit from improved fire performance. At the same time, there should be no inference of "good" or "bad" fire behavior of a given component relative to similar ones in another vehicle. The particular components are also chosen (in part) so as to reveal the range of behavior to be seen as a result of varied mass, shape, construction and constituent polymers; in this way they help assess the adequacy of the flammability test method applied here.

2) Factors Influencing the Burning Behavior of Thermoplastic Objects

The complexity of the burning of thermoplastic objects was briefly indicated above; here we develop those ideas further. The principal concern is the rate of development and intensity of the fire. These are described by the heat release rate (kW) as a function of time, with an emphasis on the peak heat release rate and the time at which this peak occurs. These last two measures are direct indicators of the threat that the burning object poses as a potential participant in a growing vehicle fire. It is assumed that the object burns long enough (tens of seconds) to have the capability to ignite other objects subjected to its fire plume or radiation.

For an object of arbitrary size and shape subjected to a flaming ignition source³ that is smaller in extent than the object itself, the pertinent factors fall into two broad categories, those external to the object and those internal to it.

External Factors. The first of these is the flux pattern imposed on the object by the external ignition source. This source is assumed here to be a fire plume, thus the flux pattern interacts with the shape of the object and the relative placement of igniter and the object. If the igniter is below the object, its fire plume splays out over any surface which its buoyant upward flow causes it to encounter. If the igniter is atop the object, a minimal amount of its heat will be transmitted to the object. Other placements tend to be intermediate. The required heat exposure area for object ignition is quite small in general, being of the same order as the object wall thickness in the area of igniter contact. On this area there is a minimum flux for ignition that is primarily dependent on the polymer involved; this internal factor is discussed below. Portions of the igniter flux pattern which are below the minimum flux for ignition of the polymer will pre-heat the material and thereby accelerate flame spread over its surface. (Flame spread is an extension of the ignited area in which the flames on the igniting area supplement and eventually replace the heat flux from the external igniter. This supplementary effect is most efficient when flames are spreading in the same direction in which their gases are flowing, e.g., upward; thus upward flame spread is typically faster than that in other directions.)

An igniter which imposes a high flux on a large portion of the surface of an object will get that fraction burning quickly and tend to yield a rapid peak in heat release rate. In principal a smaller igniter (yielding an equal heat flux but on a smaller area of the object thus igniting that area in the same time) could lead eventually to the same heat release peak. However, the smaller igniter requires an extended period of flame spread in order for the burning area to catch up to that produced by the larger igniter. During this time, areas ignited early might burn out (depending on object wall thickness) so that an equal peak in heat release could be unattainable.

A second external factor is relevant only to thermoplastic objects; this is the placement of the object relative to any melt/drip pool fire it produces. The source of the melt/drip material is, of course, those portions of the object itself heated sufficiently to cause the local polymer viscosity to drop sharply. For some common automotive polymers, the material which drips from a flaming region of the object will itself be flaming. In a vehicle fire, this melt/drip material could fall directly to the ground, as much as a half meter below the object or it could be captured by other surfaces of the vehicle much closer to the burning object. The drip material tends to form a pool fire (or something more irregular if falling on complex surfaces) with the potential to feed heat back to the burning object. This will be most effective in enhancing the heat release rate of the object if the pool fire plume overlaps the object, particularly if the pool flames accelerate flame

³A flaming source is assumed here since that is what is used in this study. If the source were a localized electrical short, the same considerations would apply. The ignited area on the object would most likely be smaller, perhaps much smaller, and the time to reach a peak in the heat release rate would be extended.

spread over the object. On the other hand, a small pool fire on the ground may have essentially no interaction with a burning object higher in the vehicle. The "reach" of the pool fire depends on its diameter and the properties of the burning melt: it is typically a small multiple of the pool fire diameter.

Even if there is no direct interaction between the pool fire and the burning object, the pool burning represents an enhanced heat release rate effect. Essentially, melt run-off provides an enhanced area for burning of the material. Local heat feedback from the flames on the burning object produces an excess of burnable material which is then consumed in the pool fire. The heat release rate from the pool fire can exceed that coming from the object (roughly speaking, when the burning pool area exceeds the burning area on the object).

The third external factor relevant to the burning of a thermoplastic object (or, in this case, any type of object) is the extent of heat input from the surroundings. As was alluded to in the Introduction, the surroundings may not be a passive absorber of heat radiated from the burning object. Some or all of the other materials/objects surrounding the item of interest may themselves be hot and/or burning. Even though their fire plumes (if they are burning) do not touch the object of interest (by assumption here), they irradiate its surface. This accelerates both the heating of non-burning portions of the object (raising flame spread rates onto these areas) and the heat release rate from burning areas on it. The net result can be a strongly enhanced burning process with a higher heat release peak achieved sooner; the effect is proportional to the level of heat flux received from the surroundings.

Internal Factors. The first of these is a grouping of parameters which together comprise the inherent flammability of the compounded polymer resin used in the object of interest. The directly pertinent measures of flammability are ignition delay time and heat release rate per unit area, both as a function of incident heat flux (typically measured with a varied radiative flux). Ignition delay time depends on polymer stability in the manner described in the Introduction; this chemical bond strength dependence is summarized somewhat approximately in an ignition temperature for the material. Ignition delay also depends on the amount of heat a slab of material must absorb per unit area in order for its surface to reach this temperature. The appropriate measure of this is the thermal inertia which is a product of density, heat capacity and thermal conductivity for a thick material (here several mm); for a thin material (here 1 mm to 2 mm), slab thickness replaces thermal conductivity. If the compounded polymer resin includes an additive, it may passively affect these thermal properties (approximately, in proportion to the mass fraction of the additive) or, if the additive is a heat-sink-based flame retardant such as alumina trihydrate, it may boost the effective heat capacity of the resin.

Heat release rate is the product of mass burning rate and heat of combustion per unit mass of material burned. Mass burning rate varies inversely with the heat of gasification of a material, which is a combination of the sensible heat required to raise the temperature of the material to its burning surface temperature and the heat to turn the solid into combustible gaseous fragments. The burning surface temperature is typically a few tens of degrees above the ignition temperature

so that essentially the same material degradation chemistry is involved. The chemical nature of the material, principally its elemental composition, determines its heat of combustion. This can be reduced via additives which promote char formation or partially suppress gas phase oxidation reactions. The polymer resin can also be diluted by the addition of inert solids. If those solids stay physically in place while the resin in an object burns, as is the case for fibers of sufficient length, for example, they will form an insulating barrier between the flames and the solid, thus slowing its rate of burning.

The next pertinent internal factor is the melt viscosity of the polymer resin. This obviously affects if and how the part melts down to form a separate pool fire under the influence of external heating and self-generated flames. As such it interacts with the placement of the external heat source and the part shape. A part composed of a resin having a low melt viscosity (or forming such a melt upon degradation)⁴ will exhibit a rapid downward flow on the heated plastic portions, with the outer layers running off first. With many current polymers, this melt/drip material is flaming and so it forms a pool fire below the object.⁵ As was pointed out above, such a pool fire extends the area of burning material and provides the distinct possibility of interaction with the burning object itself. In the worst case, this pool fire will accelerate fire growth on the object as well as enhance its local heat release rate per unit area. Since this also accelerates the rate of melt/drip feeding of the pool fire, the result can be a strongly spiked fire growth process.⁶

A part composed of a high melt viscosity resin will show little deformation or melt/drip behavior. Its burning behavior will be dictated by its original shape.

⁴Polymer melt viscosity is a strong function of both molecular weight, which may be strongly reduced during degradation (depending on the degradation mechanism of the polymer), and of temperature (relative to its glass transition temperature).

⁵This melt material carries away much of the heat the object receives from the external source (or from its own flames anchored to some other part of the object). If the melt/drip material were not flaming and thus did not form a pool fire, it could provide a diversionary path for fuel, lessening the total heat release as the object burns. Whether or not this is a practical approach is not clear at this time.

⁶The ultimate in worst case behavior for a thermoplastic component amid an array of other components (as in an engine compartment) would be for it to melt/burn so rapidly as to release all of its heat content in a time of the order of the ignition times of the surrounding components (typically tens of seconds). Such rapid burning would yield the largest flame volume and the maximum number of other objects being ignited. This case was not approached for any objects in this study. Gasoline provides an interesting contrast. It is typically so fluid and volatile that a brief spill can burn out in a time that is short compared to the time required to ignite solid objects encompassed in its flame volume. Any pooling of the liquid will extend its burn time and its chance of igniting other objects.

A part composed of an intermediate melt viscosity resin will deform and collapse slowly as it burns, forming a lumpy "pool" fire which does not spread laterally. If the part includes inert (e.g., metallic) structural elements, a substantial portion of the resin may cling to this as it burns. Thus the possibility of an interacting pool and part fire still exists.

Finally, consider the shape and the total mass of the part. There are myriad variations here which will affect the heat release pattern from a burning object. For example, if the part is compact, the igniter flame may encompass most of its external surface so that fire spread on the object is of little relevance to its heat release behavior. On the other hand, for an extended part of the same mass, its heat release behavior may be heavily influenced by the rate of flame spread over its surface. Increased mass for either case will tend to extend the duration of burning. Part shape also affects the extent of radiative interchange among burning surfaces; this influences both flame spread rate and post-ignition mass burning rate. A concave burning surface is more adiabatic (i.e., it loses less radiation from the burning surface) than a convex surface. This enhances the burning of the concave surface, at least up to the point where its curvature inhibits air access to the flames. In addition, shape interacts with the manner in which a part may melt down and collapse.

With all of these factors bearing on the intensity and duration of the fire that results from igniting a thermoplastic part, it is apparent that there is no unique measure of the fire behavior of the part. In view of this we have tried here to elicit behavior toward the more severe end of the spectrum while still retaining realism. However, it should be noted that virtually all of the tests here involve the part in isolation and thus free from heat inputs that would be provided by other burning objects. Only one object was tested with the added influence of external radiating surfaces interacting with the object (and the result was substantially enhanced burning).

In describing the test results below, an attempt is made to interpret (at least qualitatively) how the various factors described above impacted the measured flammability behavior.

3) Experimental Details

Test Objects. Table 1, derived from data provided by General Motors, lists the parts from the vehicle tested in this first series. It also gives the nominal type of principal polymer, where this could be determined, and the mass of organic and inorganic components. Figures 1 to 12 show photos of each part; the number included on several of the photos corresponds to the component number in Table 1. Fig. 13a, b, c, also from General Motors, show the approximate location and relative size of the parts in the vehicle (not all of the parts shown in Fig. 13 were tested in this portion of the B.10 project). Most of the actual parts tested in this study were new; a few were salvaged from the crashed vehicles (damage to these was minimal).

Several of the parts in Table 1 are from the engine compartment. Note that in Fig. 13 many of these objects are clustered on the driver's side or are near the bulkhead between the engine and passenger compartments. They were chosen because they comprise major solid fuel masses and also lie in a potential fire path from the battery area toward the bulkhead. (The headlight

assembly was chosen because it was forced into the periphery of this mass of parts by the impact during the full-scale crash test in Project B.3. The hood liner was chosen because its position at the top of the engine compartment makes it a probable participant in most engine compartment fires.) One front end crash of this vehicle produced a fire in the battery area; a fire test of the crashed vehicle was initiated in this area also. The vehicle crash and fire test program is described in detail in Ref. 2.

Two parts in Table 1 are pertinent to a rear end fuel fed fire; a test of this nature was also run for this type of vehicle [Ref. 2]. That test showed that the fuel tank and the rear wheel well liner were significant participants in the particular scenario examined.

Also listed in Table 1 are certain components from the passenger compartment. Typically, the threat to the passengers is not instantaneous upon the penetration of some portion of a fire plume into the interior. Rather, that plume ignites other materials in the interior causing a growing fire there. The net accumulation in the interior of heat and toxic gases from all sources, exterior and interior, determines the threat level.⁷ Thus the fire growth behavior of interior parts is also pertinent to the time line of development of a threat to the passengers.

The interior parts chosen do not comprise a comprehensive selection of the items at risk, but they are informative. The instrument panel assembly (which here included the HVAC unit, air ducts, front fascia and topper pad, as well as the sound insulating pad that lays against the bulkhead, but not the instrument cluster that mounts in the instrument panel or the knee bolster pads) is of interest because it resides immediately inside the forward bulkhead that separates the passenger compartment from the engine compartment. The three major, designed-in holes in the bulkhead of this vehicle all open into the space occupied by the HVAC/heater unit. Flames penetrating any of these holes would likely start a fire in this unit which could spread into the air ducts and topper pad. In the rear end fuel fed fire test [2], a significant factor was involvement of the rear seat; here a front seat is examined. In any fire the hot gases entering the interior rise quickly to the top of the passenger compartment. Thus the component there, the headliner, is threatened. Rapid fire spread in this area typically signals the onset of flashover which implies untenable (non-survivable) conditions.

Flow calorimeters. Two measurement devices were used in the study reported here. Both are calorimeters which work on the oxygen consumption principle, i.e., that all common organic materials yield approximately the same heat evolution per unit mass of oxygen consumed in their combustion [Ref. 3]. Thus one can measure the rate of heat release evolved from the burning of an object by capturing the plume of evolved gases and measuring the mass flux deficit of oxygen it carries relative to ambient air. The variability among organic compounds with respect to heat evolution per unit mass of oxygen consumed is about $\pm 5\%$; this sets the maximum level of

⁷In principal, actual fire penetration into the passenger compartment is not needed for the attainment of life threatening conditions. Accumulating toxic smoke alone could achieve this condition.

accuracy achievable in such measurements. A calibration test using natural gas was run before each test here and used to make any minor adjustments to the data as a result of instrument drift; thus the results should, in general, be accurate to $\pm 5\%$.

As was noted previously, heat release rate (typically reported in kilowatts) is the most pertinent measure of the size of a fire; it is this quantity which drives the plume of hot, toxic gases and plays a major role in the rate of growth of fires in more complex situations involving multiple flammable objects.

The two devices used here were coupled together, using the same gas analysis instrumentation. They also rely on a common blower to draw in the fire plume. Figure 14 shows a schematic of the two parallel hoods and mixing ducts from which gases are sampled. The smaller hood, 1.22 m (4 ft.) wide is attached to a 0.23 m (9 in.) duct via a mixing section. It is rated at 100 kW or less peak heat release rate. The larger hood, 3.05 m (10 ft) wide is attached to a 0.46 m (18 in) duct via a mixing section of the same design. It is currently rated at 500 kW peak heat release rate but is upgradeable to 1 MW. In both cases the gases are sampled twelve diameters downstream of the mixing section to assure uniformity and a well-developed turbulent flow profile. At the sampling region, measurements are also made of temperature and centerline velocity (determined from a differential pressure transducer) so that the mass flow rate can be inferred. The gas measurements, which include oxygen, CO and CO₂, are made after particulate filtration and thorough removal of the water content. Both devices are essentially equivalent in design (except for scale in the case of the smaller calorimeter) to the calorimeter specified in ASTM E-1537.

Each system is calibrated using natural gas of known energy content at several flow rates to an appropriate burner placed under the hood. A calibration run at a single burner level is also made before each part test. This is used to make minor adjustments to the heat release data obtained.

A fire plume entrains a considerable amount of excess air; at the flame tips it is approximately ten times that needed to consume the fuel gases. This has two implications for this type of calorimetry. First, the oxygen depletion level in the captured plume is small so that the oxygen meter used must be very precise. Second, the burning object would ideally be placed such that the tips of the flames it produces would always be at the inlet level of the hood. This would minimize the excess dilution of the plume while precluding artificial quenching of the flames such as might occur if the flames were swallowed by the hood duct. As a practical matter, the burning of real objects is strongly time-dependent; one must estimate ahead of time the likely peak heat release rate then place the object vertically relative to the hood inlet or select the hood flow rate such that heat release information is not excessively diluted by electronic and other noise in the system. The success at doing this with unknown objects varies and thus also does the relative noise level in the data.

In the tests done here, a further factor influenced signal to noise ratio. Two pressure transducers were available for use in the duct flow velocity measurements. They differed in range; the one

with the greater range was significantly more noisy and this noise carried into the heat release rate computed using these data as inputs. It was necessary to switch to the higher range device in some tests because of the high hood flow required to swallow a large fire plume.

Both of these sources of noise were countered in the tests by sampling the data signals at a relatively high rate (typically every three seconds) so that over the course of a test lasting ten or more minutes, typically, the level and trend of the actual heat release rate is clear. Brief, sharp peaks in heat release rate are somewhat uncertain in magnitude, however. In any event, a system such as this will smooth short peaks of the order of ten seconds or less in duration via dispersion in the flow lines and via instrument response times. This is not a serious shortcoming since such short peaks are unlikely to have a substantial impact in a vehicle fire.

Ignition Conditions and Burning Configuration. In post-crash situations, a given part could encounter a variety of ignition and burning conditions. For example, ignition could occur internally due to an electrical short, on the surface due to a splashed flaming fluid or the part could be engulfed by flames spreading from some other source.⁸ Each one of these varying ignition conditions could be expected to yield a different burning history from the part, depending on the time needed for flames to grow over its entire surface. Furthermore, as explained above, if the part contains thermoplastic components (and nearly every item in Table 1 does), the burning history will depend on the extent to which the flaming part interacts with its own self-generated melt/drip pool fire.

Given this inherent variability and the infeasibility of characterizing it with each part, we have chosen a standard set of ignition and burning conditions. That set is fairly severe, though it is not thought to represent a worst case.⁹ The scenario envisioned is one in which the part is subjected to a substantial (though localized) fire plume from below; the source of this fire is at a fixed distance below the lower surface of the part. There is a horizontal surface at twice this distance which captures all melt/drip material and allows it to form a potentially interacting pool fire below the burning part.

This scenario was implemented as follows. The source of the fire plume coming from below was a ring-burner (10.2 cm ID ring made from 0.635 cm OD stainless steel tubing having 12 equally-

⁸This type of variability is inherent in the burning of any extensive object subjected to a localized ignition source. It is a consequence of the parallel processes of fire growth on the surface of the object and burning of the areas already ignited. It may be accentuated in the case of complex, asymmetric parts with variable material thickness.

⁹Apart from shape and localized ignition considerations, there is an issue of whether a part will burn as intensely in isolation as it will in the midst of a developing fire in a crowded engine compartment, for example, where various other hot surfaces may be feeding heat back to the part of interest and accelerating its burning. This was explored briefly for a battery, as discussed in the text.

spaced holes, 0.132 cm dia.; holes pointing inward/upward at 45°). This burner was operated with a steady propane flow of 5 L/min (measured at normal temperature and pressure, NTP), set and controlled by a parallel pair of Brooks 5850 mass flow controllers, factory-calibrated for propane.¹⁰ This flow corresponds to a heat release rate of 7 kW and yields a conical, essentially laminar fire plume which tapers from a base diameter of approximately 10 cm to a narrow tip at a height of approximately 30-35 cm.¹¹ This burner was placed 7.6 cm below the lower surface of a part; it was left in place and on throughout most of a test (in the spirit of tending toward more severe test conditions; when it was turned off, it was at a point where it was irrelevant to the behavior of the part). Each part was in its normal orientation that it would have in a vehicle and was supported in a manner approximating its normal means of support. A catch surface was placed 15.2 cm below the lower surface of the part. That surface was made of a 1.3 cm thick layer of cement fiber board (Durock in nearly all tests).¹² That catch surface was located in a 61 cm diameter steel pan placed atop an ATC 6005 weigh cell which allowed measurement of the mass of material flowing off of the test part (and subsequently burning). The part itself was in most cases also being weighed during a test with a pair of Omega LC2 scales. Figure 15 is a schematic of the implementation of this test configuration as applied to a battery.

Figure 15 shows that there were (as many as) three total heat flux gages (Medtherm 20679) looking toward the test object. These were Schmidt-Boelter type gages cooled with water at approximately 85°C to prevent condensation on the sensor surface; the gages were calibrated at this coolant temperature with a radiant heat source. The gages were intended to give a measure of the level of heat flux the burning object could transmit to surrounding objects. The gage looking down from above typically ended up in the fire plume from the burning object (plus that from the igniter in some cases) and measured a combination of convection and radiation. The two side-looking gages typically saw only radiation though occasionally a fire plume reached them as well, adding convective heating. Note that the radiative fluxes are maximized by close placement of the gage to the burning object. At greater distances they decrease in accord with the view

¹⁰Certain trade names and company products are mentioned in the text or identified in an illustration in order to specify adequately the experimental procedure and equipment used. In no case does such identification imply recommendation or endorsement by the National Institute of Standards and Technology, nor does it imply that the products are necessarily the best available for the purpose.

¹¹This flow of propane is equivalent in energy content (power output) to a liquid gasoline flow of 13 cm³/min. For reference, MVSS 301 allows a post-crash liquid gasoline leak rate of up to 35 to 40 cm³/min (based on an allowed leak of 5 ounces in the first five minutes after the vehicle comes to rest).

¹²Cement fiber board has a lower thermal inertia than likely catch surfaces in a vehicle fire; these might include steel surfaces of other parts or a road surface. This implies that the catch surface used here will heat up more rapidly and sustain a pool fire sooner. This fact tends to increase the severity of the burn conditions used.

factor between the burning object and the point of measurement.

The tests were videotaped from two directions, typically at 90°, using Hi-8 camcorders. For these small objects it was usually possible to get enough light on the part so that the flames themselves were not overexposed when the part itself was properly exposed on the video tape. The tapes provided a visual record of the behavior of the test object and evidence of the extent to which its burning was affected by interaction with its melt/drip pool fire.

Instrument Panel Test Configuration. The available components of the instrument panel were tested as a group. General Motors supplied a section of a test vehicle of the same design that extended vertically from the toe pan to the top of the windshield frame; the remainder of the vehicle body, forward and to the rear, was cut away.¹³ The heart of this section is the bulkhead between the engine compartment and the passenger compartment. On the passenger side, the HVAC unit, air duct assembly, topper pad and front fascia were mounted in their normal locations; so also was the sound absorber pad that lays against the bulkhead on the passenger compartment side. The assembly did not include an instrument cluster, radio, knee bolsters or glove compartment.

The objective of this test derived from results of a fire test of this type of vehicle in the related Project B.3 [2]. There it was found that for a particular post-crash ignition scenario in which a fire originated in the battery area, the fire spread into the passenger compartment first through the windshield. However, the fire was attempting to enter through the bulkhead as well, yielding visible damage on the inside of the three holes penetrated by the HVAC air inlet, the AC coolant hoses and the heater hoses, respectively. Here the goal was to simulate the potential consequences of fire penetration through the two types of hose holes and learn the rate of development of such a fire in the instrument panel components. To simulate this, a small steel enclosure was constructed to fit over the engine compartment side of the bulkhead so as to encompass the two holes. Ceramic felt was used to achieve an adequate seal. Inside the enclosure a tubular steel burner was placed so as to direct flames at the bulkhead just below each hole. These flames, produced by a 1.5 NTP L/min propane flow, spread upward by buoyancy to cover the entire height of each hole. Air was forced weakly into the enclosure by a blower operated from a variable transformer. The air flow rate and a pair of variable area exhaust holes were used to keep the pressure inside the enclosure equal to the maximum differential measured across the bulkhead in the engine compartment fire test. This was 3 Pa; it was measured to an uncertainty of about 0.1 Pa with an MKS Baratron 398 HD pressure transducer.

This assembly was also used (first) to test another part of interest, a foam rubber sound insulation strip which lines the rear near-vertical surface of the space defined by the front fender panel (in this case, on the driver's side) and the body sheet metal frame, just in front of the front door

¹³This was cut from the vehicle used for the rear-end fuel-fed fire test. The parts tested were a mix of new components and parts salvaged from the fire test vehicle; none were significantly damaged.

frame. In contact with this, just over half way up its length, there is an opening through the body frame into the space behind the instrument panel; major cable bundles (2 cm to 3 cm in diameter) from the engine compartment (via the fender well space) pass through such openings on both sides of the vehicle. The hole in the body metal is lined with a thermoplastic feed through duct through which the cables pass; the loose peripheral space between the cable bundle and the plastic duct is filled with a flexible foam rubber so that free air flow is not normally possible. The issue here is whether the foam insulation strip forms a conduit for a fire originating below the fender well to attack the cable feed through, allowing fire penetration into the instrument panel. Here the insulation strip was held in place by two wires. The fender panel, which was not available, was effectively simulated by sheet metal shaped so as to cover and define the rear portion of the wheel well space approximately as the fender normally would. The ring burner igniter was placed 4 cm to 5 cm below the lower end of the foam insulator strip and operated in the normal manner. The test was video-taped to record the behavior of the insulator strip and the feed through was inspected post-test for fire penetration. Heat release rate was not measured.

4) Test Results

Battery. Samples of this part were burned in three different ways to help assess the range of behavior a given component might exhibit. This was the only part for which these test variations were possible in this study. Note that in all cases the battery had been drained of electrolyte, neutralized with sodium bicarbonate, rinsed with water and allowed to drain upside down for at least 24 hours.

When burned in isolation, in the configuration indicated in Figure 15, this part proved to be borderline in its interaction with its own pool fire. This led to a timewise variability in the heat release rate which was not fully reproducible. The results for such a test are shown in Fig. 16. The burning process commenced on the area struck by the igniter plume, here the full height of one long vertical side and the central, roughly 50% of the bottom area (full width but limited longitudinally by the frame supporting the battery). Flaming melt/drip behavior started in less than one minute after the igniter was turned on; the melt viscosity appeared to be relatively low so that the outer layers of the battery wall material flowed and dripped freely. The mass of lead-based battery plates appeared to have had a significant heat sinking effect on the walls; they melted through first above the plate level despite the fact that the burner heat flux was almost certainly higher near the base of the battery. By about three minutes, the bulk of the wall material in the side area struck by the igniter flame was gone (both by downward flow and by burning); this left the fire to spread on the battery case itself by lateral spread along the vertical sides, over material not heated by the igniter flame.

Lateral flame spread of this sort is a comparatively slow process, here taking roughly 20 minutes to spread around the vertical sides of the battery. It will accelerate in this case only if the melt/drip pool fire below the battery grows big enough to pre-heat the wall material and/or if the pool fire plume manages to melt down the wall material to feed fuel to itself. This is termed an

interactive condition between the object fire and its own pool fire. Note the potential for positive feedback: increased heating from the pool fire can accelerate the feeding of the pool fire with melt/drip material; this causes the pool fire to grow and heat still more of the battery, accelerating its fire growth and melt/drip rate, etc. Potentially, via this positive feedback, the fire can grow strongly until limited by fuel availability. The interactive effect is capable of its biggest impact in cases such as this where there is a substantial flame spread component to the fire response of the vehicle part. In contrast, the effect will be reduced in cases where the ignition source is large enough, in relation to the vehicle component, to essentially engulf it initially, without the aid of a pool fire.

A battery is a component containing a large inert mass, in this case mainly the lead plates. This mass is largely, though not totally, impervious to the growing fire. While that mass may be inert in terms of fuel contribution, it is not irrelevant to the fire development process. Here the plate bundle stayed in place and served as a deflector of the igniter flame, a heat sink and an obstructive volume around which the fire was forced to grow. Another significant role was as a holding surface for molten polymer resin. All of these effects had a strong effect on the rate of melt/drip flow to the pool fire and on the rate of burning of resin before it dripped off the battery mass.

Three batteries were burned in the manner described above although quantitative heat release rate data were obtained only for the case shown in Fig. 16. Inspection of the video tapes for the other two tests shows that one progressed very much like that in Fig. 16 and the other differed significantly. The net heat release rate from the battery shown in Fig. 16 is comparable to that from the igniter itself for a long time as the fire spread slowly along the vertical sides of the battery case; the battery plates remained intact as a monolithic mass which stayed in place on the support bars.¹⁴ The drip rate to the pool fire was low and the flame height on the pool was roughly half the distance between the pool and the battery base; this was insufficient to allow a strong positive feedback to occur. Late in the test (ca. 1300 s) the pool fire grew to an interactive level and the net heat release rate more than doubled. This late growth of the pool fire appeared to be due to an enhanced melt/drip rate involving the two corners of the case away from the side with the igniter under it. In this test, all four vertical corners of the case appeared to yield an acceleration in the melt/drip rate but that from the two corners nearer the igniter did not cause the pool fire to grow (for reasons which were not apparent). In contrast, one of the three tests of this

¹⁴One secondary phenomenon seen during the burning of all of the batteries is worth noting. Despite their having been drained of the rinse water used to clean the inside of the battery, several drops typically remained. As the battery opened up on the bottom, drops of water fell onto the pool fire, flashed into steam and caused a very brief flare-up in the heat release rate (too brief to be resolved by the measurement system). The flare-up is caused by the sudden increase in area of burning fuel; this phenomenon has been seen previously in the burning of an oil layer on top of a water layer. It is another demonstration of the role of burning surface area in the heat release rate of a fire. If the batteries had been full of electrolyte, the effect would have been of another type, given the volume of that fluid; the pool fire would have been at least temporarily extinguished.

type did yield pool fire growth and interaction repeatedly (associated with flames on the vertical corners) and three distinct periods of strong interaction and enhanced heat release rate (as judged by flame volume and height). Each time, the interactive fire died back to a non-interactive state within a few minutes. Evidently a borderline case such as this is sensitive to small perturbations. The interaction in these battery tests could have been enhanced by lessening the distance between the pool fire surface and the base of the battery; it appeared that reducing this distance by a factor of two in this case would have led to a steadily interactive condition.

Figure 16 includes data on the weight of the battery (plus holder) and on the weight of the pool during the fire. The most interesting feature of the data are that they show a substantial difference between the weight lost from the battery and the weight gained by the pool fire. For example, of the first 0.2 kg of weight lost from the battery, only 1/4 of this is seen as pool mass. This is somewhat deceptive. Mass is continually being lost from the battery by a combination of burning and melt/drip to the pool surface. This latter mass is adding to the pool total mass but it too is losing weight by burning (when the pool weight hits a plateau the two rates are equal). There are three unknowns in this mass balance situation and only two sources of known numbers so the problem cannot be fully resolved as a function of time as to the contribution from each mass source or sink.¹⁵ The weight data do confirm that the interactive pool fire (after 1400 s) results from an accumulation of fuel mass in the pool.

The heat release rate from the battery/pool fire combination (minus the igniter) in the non-interactive state is only in the range from 5 kW to 8 kW; this is comparable to the igniter itself. In the interactive state, as seen in Fig. 16, this heat release rate can double or triple. This interactive state occurred late in the fire when there was little further fuel remaining on the battery. An earlier interactive state which boosted the fire growth rate on the battery when most of the fuel was still present could lead to a larger heat release rate. An indication of this is seen in the results from other battery tests discussed below.

This battery is normally used with a four-sided, open-top, plastic "cover" around it in the vehicle; see Figure 2. This cover fits tightly around three vertical sides of the battery but has a gap on one long side of the order of 1 cm in width between the cover and the battery wall. A battery plus cover combination was tested in the same configuration as that shown in Fig. 15. The igniter was placed on the side with the gap between the battery wall and the cover wall so that some of the igniter flames flowed up through this gap. This is a worst case condition in terms of speed of fire involvement of the material on this side of the battery; the cover wall, in particular, was heated on both sides by the igniter flame. In addition, this cover added 0.36 kg of polypropylene as fuel to

¹⁵A possible way in which to get the necessary additional information would be to repeat a given experiment but quench the pool flames to eliminate the unknown mass loss rate from the pool due to its burning. This was not done here (and would not have worked well with the battery fires given their variability in behavior).

the fire, a significant addition.¹⁶

The behavior of the battery plus cover combination is shown in Fig. 17. The increased intensity of the fire and its more rapid development, relative to the isolated battery in Fig. 16, is striking. The difference here is in the degree of interaction facilitated early in the fire by the melt/drip material from both the battery cover and the side of the battery. This quickly led to a pool fire tall enough to assist in spreading the flame around the sides of the battery cover. This cover material had a sufficiently low melt viscosity (though evidently somewhat higher than that of the battery case) to allow downward flow of thick streamers which subsequently melted further onto the pool surface. This led to a continuing increase in the pool fire diameter which, in turn, facilitated more fire growth around the sides of the battery. At the heat release peak the battery was burning on all sides though not necessarily on all of its exposed surface area. The heat release rate subsequently decreased when the pool fire began to shrink. Soon thereafter the block of battery plates failed in shear and slumped downward. This motion caused a layer of insulator to pull off of one of the rails supporting the battery and block part of the pool fire, decreasing the heat release rate.

The weight data in Figure 17 were truncated by a computer failure but before this they once again show a tendency for the weight gain rate of the pool to lag behind the weight loss rate of the battery, for reasons explained above.

Note that the peak heat release rate in this fire approached eight times that of the igniter alone and it occurred much sooner than in the case of the battery burning in isolation. The battery and its cover are, in practice, so closely coupled in a vehicle as to act like a single component so, in effect, the behavior just shown is that of this "system" in isolation.

As was indicated above, any component in a vehicle may be exposed not to just the heat input from a single ignition source, but rather the inputs from multiple items burning around it. The radiative input from these other objects could substantially affect the burning process of the component of interest, particularly for a thermoplastic object which can be melted by these inputs. Thus the behavior of the component in context may differ from that which it exhibits in isolation. There are, of course, an infinite number of variations of contextual scenarios which one could construct. Only one has been investigated here.

To simulate the effects of nearby burning objects, the battery (alone, no cover) was placed inside a sheet metal box, open on the bottom which enclosed it loosely. On the long sides of the battery the box wall was about 9 cm away; on the short sides of the battery the box wall was about 5 cm away; the top of the box was 10 cm above the top of the battery with a peripheral gap of about 3.5 cm to allow free flow of air through the box. One long interior side of the box was lined with 1.3 cm thick ceramic felt insulation; the interior of the top was similarly lined. This insulation was

¹⁶The mass of plastic in the battery case itself is not available but it is estimated, from surface area and approximate wall thickness, to be no more than about twice the mass of the battery cover.

chosen as an inert radiating surface. The layer on the long vertical interior side of the box was heated by means of a propane gas burner (line burner) which had a linear array of small jets aimed upward, nearly tangential to the insulator surface; this caused that surface to glow and radiate toward the exposed side of the battery. The insulator layer on the top interior surface of the box was heated by the flames from the usual ring igniter, placed in its usual location below one long edge of the battery and by hot gases from the burner along the wall, just described; it was also heated by flames from the burning battery during the actual fire test. Prior to the fire test, a sheet metal box the size of the battery was put into its place, containing one total heat flux gage facing toward the glowing side wall (from the center of the side of the "battery") and one gage facing upward (from the center of the top of the "battery"). With both burners on at the same level of gas flow as was used subsequently in the fire test (5 NTP L/min of propane to each burner), the gages indicated a flux level of 24 to 28 kW/m² to the sidewall and 7 to 12 kW/m² to the top surface. In the test with a battery present in this box, the burner along the sidewall (whose flames did not contact the surface of the battery) was started 30 s prior to the start of the ring igniter.

Fig. 18 shows the results of this test. No heat flux gages were used here. During the test a melt/drip pool fire began below the ring igniter at about 1 minute after the start of the ring igniter; such a fire began below the opposite side of the battery at about 2.3 min. These two fires coalesced into a single pool fire at 3.5 min. The pool fire grew quickly, fed by rapid flow from the outer layers of the battery case. As the heat release rose rapidly toward 100 kW, with the pool fire appearing to engulf the entire battery, there were indications that the battery was disintegrating. The heat release rate dropped abruptly as one entire side of the case flowed slowly onto the pool surface, reducing the area which was burning. Shortly thereafter the battery plates broke apart and slumped against the sides of the box with one section falling to the pool surface extinguishing a substantial portion of it and also knocking the ring igniter out of place. The subsequent burning was a product of the highly unique arrangement of materials and components brought on by the battery disintegration.

These three types of test demonstrate that the intensity of fire achieved with a thermoplastic object is highly dependent on the circumstances under which it burns. A major factor in this variability is the degree to which the burning configuration facilitates the interaction between the object and its self-generated pool fire.

Heat flux measurements were made on only two of the above types of test. Results are shown in Figs 16 and 17. Note that two of the flux gages were at mid-height along two vertical faces and 5 cm away from their respective surfaces. The third gage was 7.5 cm above the top center of the battery; in this location it was out of the plume from the igniter. Inspection of the video tapes of the tests shows that the gages read high values only when they were immersed in flames. The noise in these readings was due to the turbulent eddies of hot and cool gases in the fire plume.

Most of the heating threat to any adjacent objects from the burning of these components is, of course, above them since this is where the fire plume goes. The results show that the fluxes there can become quite high, reaching 50 kW/m² or even up to 90 kW/m². The generic ignition curve

in Ref. 4 suggests that these flux levels can ignite other materials in a few tens of seconds. The lateral gage fluxes reached these levels only when a large pool fire was engulfing the side of the battery on which the gage was located, along with the gage itself. At other times, these lateral gages registered mainly radiant heat fluxes from whatever fraction of the side of the battery was burning. An exception is the occasional short spikes shown by the gage on the side away from the igniter in Fig. 16. These spikes appear to have been caused by flame contact. The flame here was that due to the igniter augmented by burning on the bottom of the battery; it intermittently flickered out as far as the flux gage. The radiant flux (between these spikes), even 5 cm away, was, for this component, fairly low because the surface temperature of the battery case was limited to that of melting/degrading polypropylene. The flames also radiated but they were not highly sooty and their optical pathlength was fairly short. Furthermore, much of the time the sides being seen by the flux gages were only partially involved in burning.

The generally lower level of flux to the sides would be expected to cause nearby components (in a hypothetical engine compartment) to tend to melt downward, possibly contributing to the melt pool fire from the battery. Ignition of the adjacent objects is possible but appears less likely (except when direct flame impingement is occurring for tens of seconds). A low heating rate leaves more time for resin flow.

Air Intake Resonator. This device consisted of a roughly rectangular, hollow box made of polypropylene; the resin was 20% filler by mass. Attached to this box at approximately 90° relative to each other were two EPDM rubber ducts; see Fig. 3. For the flammability test done here, this part was mounted to a piece of steel angle by the normal attachment points (on one edge of the box) used in a vehicle. The orientation was also that normally found in a vehicle; this leaves one duct pointing downward and the other horizontal. The outer end of the horizontal duct, normally attached to the air intake manifold of the vehicle was supported at one point. The ring igniter was placed 7.5 cm below the bottom of the box and at a location where the flames would impinge on two vertical surfaces, forming a 90° corner where the box structure protruded to attached to the horizontal duct; a substantial fraction of the igniter plume splayed across the bottom of the box. The bottom of the box was 15 cm above the "pool" surface. Only two heat flux gages were used; one above the box (7.5 cm above its top surface) was several centimeters away from a vertical centerline through the igniter. The other gage was in the same vertical plane as the back edge of the supported side of the box and was 10.8 cm above the "pool", looking horizontally toward it.

Figure 19 shows the test results. The filled polypropylene appeared to have an effectively much higher melt viscosity than that used in the battery; the outer layers of the box surfaces did not readily flow downward. Instead, the material seemed to foam slightly then, at approximately 130 s, the bottom of the box sagged downward, opening up the interior as it fell in flaming globs onto the Durock surface; portions were slowed briefly by the igniter ring. The fire grew rapidly as the inner and outer surfaces of the sagging walls and box top ignited in response to flames from the igniter and the burning material in the irregular pool fire. The bulk of the box then fell to this pool surface. One of the rubber hoses was engulfed while the other remained on the periphery,

becoming involved much more slowly in what had turned into, with the downward collapse of the box, a lump filled pool fire (with no significant part of the object remaining in the original elevated position above the pool). The weight data in Fig. 19 reflect this sequence.

The lack of any inert internal structure to this part led to its relatively rapid collapse onto the "pool" surface. The burning area during the collapse was large, leading to a rapid, high peak in heat release rate. The relatively high melt viscosity appeared to help extend the surface area available for flaming, as did the ignition of interior surfaces once the bottom opened up. This seemed to compensate for the lack of an interactive pool fire and implies that simply increasing the melt viscosity of a resin may not assure a strong decrease in heat release rate. Melt viscosity impact on burning behavior interacts with the pre-melt surface area available for burning. The rubber parts appeared to retain their shape much better and to burn more slowly than the polypropylene parts; this was probably a consequence of the differing polymer degradation chemistry of the rubber.

The heat fluxes are similar in level to those seen for the batteries. Once again the highest fluxes are upward. Some of the early rise in the flux to the top gage was probably due to interaction with the igniter plume which was deflected toward the gage by its interaction with the part surfaces; later the flux to the top gage is due primarily to the pool fire plume. This is also true of the side-looking flux gage; it ended up engulfed by the pool fire.

Headlamp Assembly. This is a single molded unit, primarily polycarbonate, which incorporates both the headlamp and the turn signal/parking light; see Fig. 4. It was mounted horizontally to a piece of steel using the three screw holes on the back of the assembly which normally hold it in a vehicle. The ring igniter was 7.5 cm below the approximate center of the bottom of the assembly; the bottom of the assembly was 15 cm above the Durock pool surface. The igniter flames splayed across the bottom and up the front and rear sides. Two heat flux gages were used. One was 7.5 cm above the sloping top of the assembly, more or less on the axis of the ignition burner. The other was mounted horizontally at the half-height of the headlamp, pointed toward the parking lamp side, and was 6.5 to 7.5 cm from the nearest point on the curved surface of the this side.

Fig. 20 shows the test results. The viscosity of the polycarbonate resin was rather high. The bottom of the assembly sagged downward atop the ring igniter and then onto the Durock pool surface. The interaction with the burner disrupted and deflected its flames to the rear of the assembly which then sagged downward from its rear support points onto the burner. It slowly softened and sagged further to the Durock with the burner, which did not move, essentially ending up in the middle of (surrounded by) the molten, burning mass. The burner flame did force a strong flaming response from the resin during the collapse process (and to a lesser extent after the collapse) since the resin essentially surrounded this burner flame. If the burner flame were not present, it is probable that this resin, which chars appreciably as it burns, would have burned substantially slower. The high resin viscosity and its charring tendency both contributed to the fact that the assembly, as it burned on the Durock surface (with essentially nothing left in the original elevated position) remained an amorphous lump, several centimeters thick, with no

tendency to form a burning liquid pool. The weight data are dominated by the physical collapse of the assembly onto the "pool" surface. Prior to this they again indicate more rapid weight loss from the object than weight gain by the pool, implying a substantial contribution of burning to weight loss.

The heat flux to the upper gage was almost certainly due in large measure to the igniter, though it was supplemented by the flaming on the headlamp assembly. It is likely that, in the absence of the igniter flames, the flux to this gage position would have been significantly less. The other gage was never immersed in flames but should have had a clear view of the radiation from the fire plume from a distance of 10 cm to 15 cm. It registered nothing of significance which suggests that it was not properly connected to the data system in this test.

Brake Master Cylinder. This part included only one polymeric component of consequence, the brake fluid reservoir, which is made of polypropylene. This reservoir is located atop the metallic master cylinder. It is small in both mass and in physical extent (roughly 13 cm long, 8 cm high and 6 cm wide); see Fig. 5. In this study it contained no brake fluid. It was mounted horizontally using the two bolt holes on the master cylinder flange that normally attach the unit to the brake vacuum booster housing. The igniter ring was 7.5 cm below the horizontal centerline of the master cylinder itself and thus was 10 cm below the base of the fluid reservoir. The centerline of the master cylinder itself was 15 cm above the Durock surface. Two flux gages were used. One was 7.5 cm above the top center of the fluid reservoir, looking downward; the other, looking horizontally at the fluid reservoir, was 5 cm from its lateral center.

Fig. 21 shows the test results. This was a case in which flame spread on the part played a minimal role; the igniter flame engulfed perhaps 2/3 of the reservoir surface initially. As the part softened and contracted, the igniter flame fully engulfed it. The resin viscosity appeared to be roughly comparable to that of the battery case so that the outer layers ran downward and over the metal cylinder body before dripping to the Durock surface. The bulk of the reservoir slowly sagged onto the top of the cylinder as it softened. The area available for resin burning thus was shrinking on the reservoir itself but increasing on the cylinder surface and on the pool surface. Overall the burning area grew, increasing the heat release rate. By about 5 min into the test, the pool fire was large enough to provide a weakly interactive condition with the resin burning as it flowed over the cylinder, i.e., the pool flames were reaching the bottom of the cylinder. Note, however, that there is not a great deal of synergistic boosting of heat release rate possible in conditions like this since the cylinder was already immersed in flames from the igniter. The flames from the pool fire provide some boost in the convective velocity past the burning part and some increase in the flame volume radiating to its surface. With the relatively small pool fire seen here, these effects

are secondary.¹⁷ Another possible factor in the slow increase in heat release rate for this particular part was the heating of the metal cylinder. As it heated progressively it would become less of a heat sink to the burning resin flowing over it, thus allowing that resin to burn faster. In any event, the net heat release rate from the object itself only rose to the level provided by the igniter, due for the most part, to the small polymer mass available. The weight data are noisy due to the small mass change but they show the usual higher rate of weight loss from the object than gain by the pool.

The heat flux to the top gage was again strongly affected by the igniter since it was immersed in that flame from the beginning; the object flames supplemented it to a limited extent by boosting the flame volume it viewed. The lateral-looking gage provided no results due to a data failure.

Wiper tray. This is a long, crescent-shaped object which stretches the width of the engine compartment of this vehicle; it is part of the fresh air intake system and it normally contains the linkages which move the windshield wipers (these were omitted here). In the vehicle it sits atop the forward bulkhead and at the base of the windshield, covered with a plastic grille which was not tested here. Given the length of this part, it was decided to cut it in half and thus test it twice. Due to asymmetric variations in the tray-like shape, the two sides are not completely identical. They are, however, both made of essentially the same thickness of sheet molding compound, based on glass fibers. Fig. 6 provides top and bottom views. For testing, half of the tray was attached horizontally to a vertical piece of stainless steel sheet metal that approximated the role of the structure to which the tray is mounted in the vehicle; any gaps along the tray/sheet metal juncture were stuffed with ceramic wool. The normal bolt holes for mounting the tray in the vehicle were used here. Because of the glass fiber content of the part, no melt/drip behavior was expected and no weight data were taken.

The igniter placement was somewhat problematical given the irregular surface of the tray bottom; it was placed approximately 4 cm below the nearest point on the bottom of the tray. A Durock surface was 7 cm to 8 cm below the tray but it played no role in the fire behavior.

Lateral fire spread along the surfaces of this part appeared to play a significant role in the engine compartment fire test conducted on this vehicle [2]. Thus an attempt was made here to measure lateral flame spread rates away from the area of igniter impingement. Six thermocouples (bare junction, chromel/alumel wire, 0.013 cm in diameter) were placed along the tray surfaces (passing through small holes drilled through the tray wall). Four had their junctions on the outside, 2 mm to 3 mm off the surface; these were arranged as two pairs 13 cm apart horizontally on either side of the igniter. Two were on the inside, again 2 mm to 3 mm off the surface, set up as a pair 13

¹⁷In separate laboratory tests using the NIST Cone Calorimeter to measure heat release rate, blocks of polypropylene were burned with varying degrees of overlap between the object fire and its pool fire. The blocks were small so that flame spread over them did not play a role. The maximum boost in heat release rate, with extensive flame overlapping, was 50%. These results were obtained after the igniter had been extinguished.

cm apart horizontally on one side of the igniter.

One heat flux gage was used. It was approximately 4 cm from the outside surface of the tray, looking upward at about 45° so that its sensor surface was roughly parallel to the local tray surface. The area it viewed was between two of the thermocouples on one side of the igniter. It had a minimal view of the igniter flames themselves.

In the first test, using the driver's side half of the tray, the surface relief on the bottom of the tray had a strong influence on its interaction with the igniter plume and thus on the overall fire growth process. Fig. 22a shows the results. What is not apparent in the Figure but was very evident from the videotapes was the asymmetry in the fire growth on the tray. The igniter plume went both upward, sweeping up past the front lip of the tray, and toward the driver's side, heating an area 12 cm to 13 cm more extensive on this side than on the other side of the igniter. The igniter plume was largely blocked in any attempt to flow toward the passenger side of the tray bottom by its shape; the bottom was curved sharply downward on that side of the igniter, forming, in effect, a vertical wall that stopped plume motion in that direction. As a result, flame spread to the driver's side direction was strongly favored over spread in the opposite direction.

The shape of the heat release rate profile in Fig. 22a is dominated by the flame spread process. The tray ignited on the inside and outside approximately coincidentally.¹⁸ The inner/outer flame spread moved laterally across the outer wall of the tray (wall away from the sheet metal support), with spread back toward the supported wall lagging somewhat. By about 250 s, nearly all of the surface (inner and outer) to the driver's side of the igniter (plus a much smaller portion in the opposite lateral direction) was in flames and this caused the first heat release rate peak. The thinness of the tray wall (ca. 3 mm) and its high mass fraction of glass fibers (47%; General Motors result) forced a rapid die back in heat release rate per unit area and thus in the total heat release measured here. Flame spread toward the passenger's end of the tray was essentially independent of the igniter after it had gone 5 cm to 6 cm. Because the shape of the tray was inhibitory to spread on the outer surface in this direction, the overall rate was governed by spread on the interior surface. Note that flame spread on the inner wall would be favored in these circumstances by radiative interchange among the surfaces. This appears to be what got the flame spread process past a large step downward in the outer wall. Flames then spread fairly smoothly to the passenger's side (cut-off) end of the tray causing the second peak in heat release rate.

The thermocouples did yield spread data but it is necessary to view it with caution in light of the complex, sometimes igniter-influenced spread processes. One point to note is that only in the

¹⁸Ignition inside the tray did not require spontaneous appearance of flames there. There was a 2.5 cm diameter hole through the tray wall through which the igniter flames passed. The holes are not normally open in the vehicle. A lack of easy access of the exterior flames to the interior of the tray would probably slow the initial rate of fire spread somewhat though the outer edge of the tray eventually would become a pathway for interior ignition -- the tray is covered with an open grille in the vehicle.

case of the two thermocouples to the passenger's side of the igniter did the flame front move over the thermocouples in a direction parallel to a line between a given pair. Another point is that the values obtained for spread rate from the thermocouples on the driver's side depend on the temperature level chosen (here 300 °C); for those poorly behaved cases, choice of a higher or lower isotherm could affect the number by 50%. The results are shown in Table 2. The numbers are all comparable, within a factor of two; they are somewhat less than the value observed in the actual engine fire test with this vehicle but given the roughness of all these measurements, they cannot be said to be significantly different.

The heat flux seen by the gage reached a fairly significant level, 20 to 25 kW/m²; it was above 20 kW/m² for roughly 100 s. According to the rather generic ignition behavior curve in Ref. 4, this is not likely to ignite many materials directly (a longer exposure is needed at these flux levels unless the material is very thin or is foamed). However, it will appreciably pre-heat nearby materials and accelerate flame spread on them when they do ignite.

The second test involved the other side of the wiper tray that is located on the passenger's side of the vehicle. The test was set up in a very similar manner except that the single flux gage was now about 2 cm from the front lip of the tray, looking up at an angle roughly parallel to the tray surface. Six thermocouples were mounted in analogous positions in mirror image fashion to the first test, since this side of the tray was an approximate mirror image of that in the first test.

Fig. 22b shows the heat release and heat flux results. The igniter plume again was strongly influenced by the shape of the bottom of the tray. The igniter plume ran preferentially along the tray bottom toward the passenger's side and was stopped from running a comparable distance in the opposite direction by a sharply downward step in the bottom of the tray. Once again the area initially ignited was the forward lip of the tray above the igniter position. Holes again allowed flame penetration and fire growth thus occurred on inner and outer surfaces more or less in step, with each surface aiding the other by heat conduction through the tray material. Flames spread toward the back of the tray and then laterally, with the direction toward the passenger's side being heavily favored. The peak in heat release rate came as flames engulfed the inner and outer surfaces all the way to the end on that side. Spread on the outer surface in the other direction was largely foiled by the step in the bottom surface; spread did finally occur slowly on much of the inner surface in this direction.

Peculiarities in the results of all three pairs of thermocouples made them unreliable indicators of flame spread rate.¹⁹ For the thermocouples on the outer surface, the thermocouple closest to the

¹⁹Thermocouples set just off of a fuel surface can indicate the presence of flames at that location, though it is necessary to decide what temperature is a "flame" temperature. (A value of 600 °C is used in this program.) However, the presence of flames does not mean that the local surface is actually burning. This requires a flux-dependent ignition delay time during which the surface is heated sufficiently to ignite; the thermocouple record will not indicate the ignition event per se. Using the time delay between equal temperature points (here 300 °C) on a pair of

igniter, for each pair, was immediately immersed in the igniter plume. Thus they correctly indicate flame presence but do not indicate local ignition. The pair on the inner surface indicated a very high spread rate (0.6 cm/s) which was probably a result of the ignition front moving over them in a non-parallel manner. The spread rate to the passenger's side along the front lip of the tray was measured from the video tape; the result is shown in Table 2. It is comparable to the results seen in the first wiper tray test. The peak heat flux shown in Fig. 22b is comparable to that seen in the first test. Here, however, the duration above 20 kW/m² is about 300 s. This combination is of the right order to have a chance of igniting adjacent material, especially if it is thin (less than about 3 mm thick.)

Hood Liner. This component was comprised of two layers of fibrous materials; the thinner layer which faced the engine compartment was composed of strongly charring fibers, identified by General Motors as PET. The thicker layer, normally sandwiched between the outer layer and the hood itself, was composed of cotton shoddy. This liner was also cut in half (along the longitudinal axis of the vehicle) to provide two test specimens. They were mounted to a layer of sheet metal (itself supported by a peripheral frame of steel angle) using the normal thermoplastic retainer clips found in the vehicle. This assembly was held at an angle of 21° to the horizontal, approximately the same angle that the hood resides at in an uncrashed vehicle. No melt/drip behavior was anticipated so no weight signals were recorded. Two heat flux gages were mounted at two locations on opposite sides of the igniter, 5 cm from the surface with the sensor surface parallel to the liner surface. The igniter was placed horizontally below the liner with its closet point about 5.5 cm away from it. The igniter was on the centerline of the half of the liner under test and its center was about 15 cm up from the lower edge of the liner. Six thermocouples were used in an attempt to obtain flame spread information. As above, they were arranged as pairs. The leads came through the back of the liner and the junctions were 1 mm to 2 mm off of the exposed face.

Figure 23a shows the heat release rate and heat flux results for the first test (passenger's side portion of the liner). The heat release results seem quite unremarkable, in that they are low in magnitude, but they reflect some complex processes. Note first that the heat release rate rose immediately to about 10 kW; recall that the igniter supplied 7 kW. This result coupled with inspection of the videos and the thermocouple results imply that there was very fast flame spread on the outer liner surface over some fraction of the surface. The radial spread of the flaming area was 20 cm to 25 cm in a few seconds. In 3s to 4 s the igniter produced flaming on roughly 30 to

thermocouples at known spacing to infer a flame spread rate works well in purely lateral or downward flame spread, away from any igniter plume; in such cases, the first appearance of flame is very rapidly followed by the ignition front. It can be in error for upward spread or any situation where an igniter plume confuses the issue of the time of local ignition. Putting thermocouples onto the surface could, in principle, if one knew the ignition temperature of the material, provide accurate data on local ignition time. In practice, it is nearly always extremely difficult to get the degree of thermal contact with the surface needed to give accurate surface temperature measurements.

40% of the exposed area (visual estimate from video tape). Unfortunately, the thermocouple records failed to provide much useful data on this spread rate other than to confirm that it was very fast. However, this flaming area then ceased to grow. It had spread radially to encompass the top edge of the liner; any further spread required lateral and/or downward flame spread, both of which are more difficult.²⁰ Evidently the low thermal inertia of this fibrous material [Ref. 5] facilitates rapid ignition; subsequent fire growth is minimized by a low heat release rate. Some time later, however, the thermoplastic clips began to fail, allowing the liner to pull partially away from the sheet metal above it exposing the cotton shoddy to flames which tended to curl around the liner edges. The burning of the cotton shoddy accounts for much of the series of heat release peaks that followed. At one point an organized lateral/downward flame spread process was seen spreading in a coupled manner on the front and back sides together; its rate was of the order of 0.2 cm/s, much slower than the initial rapid spread.

The heat flux data indicate substantial fluxes to both gages though the higher values later in the test are caused by the liner falling downward onto the gages in an erratic manner. The earlier, lower fluxes (12 to 15 kW/m²) are not sufficient to ignite many typical materials in an engine compartment but they will pre-heat such materials extensively and thus accelerate any subsequent flame spread. It should be noted that these flux levels probably would not be sustained if the igniter flame did not stay on. It is likely that much of this flux is from the hot liner whose temperature is boosted by the igniter. This effect is relevant to the spread of a fire in an engine compartment where the flames from any burning objects are likely to be splayed out on the hood liner. Thus, a material in this position does not have to be appreciably flammable in order to be a contributor (via re-radiation) to fire growth, though its role as such is certainly lessened by minimizing its own flammability.

The results of the second hood liner test, using the driver's side of this component, are shown in Fig. 23b. This time both flux gages were on the same side of the igniter at the same 5 cm distance from the surface. This test was marred by a false start in which the igniter was inadvertently inverted; the exposure lasted only a few seconds. A five minute cool down was allowed before the test was re-started with a corrected igniter positioning. The results are substantially similar to those in the first test. The one sharp peak in heat release rate was the result of rapid burning of the cotton shoddy on one large section of the liner soon after it fell downward. Dropping sections also caused the prominent spikes in the heat flux data.

²⁰Buoyancy turns the lateral portions of the igniter plume upward beyond some distance from the igniter centerline. In the region where the plume is still flowing radially, it creates what is termed a concurrent flame spread configuration, which, like upward spread, is fast due to good fire plume contact with the surface. Once the plume has turned so as to flow up the slope of the hood, further lateral spread across the hood requires what is termed counter-current spread where the incoming air flow at the flame front is against the direction of spread, thus slowing it. The radius at which this conversion from rapid spread to slow spread occurs is proportional to the heat release rate from the igniter.

This completes the description of the burning behavior of the engine compartment components. The next two parts are from the vehicle exterior then we turn to interior components.

Rear Wheel Well Liner. This is a thin shell-like component made from polypropylene, approximately 2 mm thick; Fig. 8 shows a photo of it. Once again there is the possibility of a significant pool fire and interaction with the burning object. The part was supported in its normal orientation from the same four points normally used in the vehicle using simple struts for this purpose. The igniter was placed in the only location where its plume could maximize contact with the part surface, below the inside of the corner where the flat side surface meets the curved surface that is concentric to the wheel when mounted on the vehicle. One heat flux gage was used. It was in the plane of the bottom of the part (thus 15 cm above the Durock surface) and also in the plane of the open side of the liner (back side in Fig. 8), halfway along the length.

Figure 24 shows the test results. The igniter plume melted/burned through the liner wall at about mid-height in 25 s. The igniter plume largely lost contact with the liner by one minute into the test as the hole through it was enlarged by burning. This burning was accompanied by a significant amount of melt/drip to the Durock surface where a pool fire began. The melt viscosity appeared to be fairly low which would permit a fairly rapid melt/drip process. However, the shape of the part meant that the spreading "ring" fire on it did not preheat material over more than a few centimeters from the flame front and the melt/drip rate remained fairly low, as did the pool fire size. This changed at about 3 min to 3.5 min when the ring fire opened the shell structure up enough to leave the remaining portions of the liner unable to support themselves. As they began to sag downward, flame contact accelerated the melt/drip rate, this increased the pool fire plume size, which, in turn, increased the melt/drip rate, etc. By the peak in heat release rate, most of the material was on the pool surface and was burning vigorously.

The peak heat flux readings are surprisingly low given the size of the pool fire. On the upward part of the heat release peak it is probable that the gage was blocked in its view of the fire by sagging material from the liner. After the peak it had what appeared to be a clear view of the pool fire from a distance of about 15 cm from the fire plume centerline. It is possible that some melt material got onto the sensor surface during the part collapse; this would greatly dampen its response.

Fuel Tank. This is roughly rectangular-shaped part made primarily from polyethylene; Fig. 9 shows a picture of the tank as seen from the top. On the vehicle, the tank is mounted to the underside of the body, between the frame rails. The fuel pump (inside the tank, attached to the white disk visible in the Figure) and fuel filter (small gray cylinder) were removed before testing. The tape on the filler neck (visible along the top edge) was also removed.

Because of the mass of this part, it was tested in the larger hood shown in Fig. 14. The mass of the object and its support were once again monitored with the same pair of Omega scales. The mass of the melt/drip pool and its now much larger pan were monitored with a GSE scale having a 91 kg capacity and 10 g to 15 g sensitivity.

Two fuel tanks were tested. The first was empty; the second contained water (ca. 8 L) as a heat sink. In both cases the tank was mounted (with steel straps similar to those found on the vehicle) to the underside of a steel sheet, larger in extent than the tank, to simulate the underbody of the vehicle. A piece of sheet metal was mounted along the side of the tank having the filler neck in order to shield it in much the same manner as does a frame rail in the actual vehicle. The tank was suspended so that its bottom surface was 20 cm above a cement fiberboard surface (similar to Durock) placed in the bottom of catch pan. The ring igniter was mounted 9 cm below the filler neck such that it would play on this item and on both the side of the tank above and the bottom of the tank around it. Three heat flux gages were used. Two were imbedded in the "underbody" steel sheet, pointing downward with their sensor surfaces flush with the bottom of the steel sheet; these were mid-length along the tank, one on each side, in the plane of the outer tank edge. The third gage looked horizontally toward the tank at the height of its side seam from a distance of 5 cm (mid-length on the side with the igniter).

Figure 25 shows the results of the test of the empty fuel tank. Note that the ordinates on the heat release rate and heat flux scales are altered from the previous figures. This is a fairly thick-walled item (ca. 5 mm to 6 mm), as compared to the previous items. It required about 40 s to show signs of surface melting and about 55 s before the first melt/drip began. The melt viscosity appeared to be low (lowest seen in this test series). The filler neck shrank inward and downward with heating, effectively closing its original opening. Flames appeared to pass by the pseudo frame rail and into the narrow space between the top of the tank and the sheet steel "underbody" nearly from the start of the test but increasingly so as the tank shrank in this area. The melt/drip fire plume reached the bottom of the tank at about 4.5 min and very soon thereafter a hole through the tank wall was noted just below the filler neck juncture. This allowed flames to enter the tank interior. By 6 min the pool fire was greater than 30 cm in diameter and the tank had an opening of comparable size. In the next minute the tank began to increasingly lose contact with the "underbody" as it sagged downward on its support straps, allowing flames to spread on the top of the tank. By 8 min, both ends of the tank were in contact with the pool fiberboard surface. The pool fire then grew to engulf the lower surfaces of the tank as the top side flames engulfed that surface and the bulk of the tank fell onto the pool surface.

The heat fluxes on two of the three gages reached quite intense levels for a duration more than long enough to ignite other materials. However, on the underside of this vehicle, few other flammable materials reside nearby. A significant concern here is the possibility of ignition of adjacent interior materials through the underbody, simply by heat conduction. At present there are no data available on the likelihood of this route.

The second fuel tank test configuration was identical except for the presence of water in the tank. The purpose of the water was to provide a heat sink, somewhat in the manner of a tank partially filled with gasoline. The 8 L of water provided a layer depth of about 2 cm in the area of the igniter. It is recognized that water has a substantially higher heat capacity (ca. 2X) and boiling point than gasoline. No heat flux gages were used since the goal was to examine the impact of the liquid layer on the early behavior of the tank fire.

No figure is presented for this test since it was stopped at an early stage (< 50 kW). The earliest signs of degradation and initial melt/drip occurred with essentially the same timing as with the empty tank but then events were noticeably slowed. The pool fire plume reached the bottom of the tank 2 min later (6.5 min vs 4.5 min above). By 8 min it was clear that flames were spreading on the top of the tank but no hole had yet appeared in the tank wall in the area where the igniter plume was impinging. A hole finally appeared after 9.5 min, above the mid-height seam (about five minutes later than with the empty tank). The hole grew radially for the next minute until at 10.5 min the pool fire began to react vigorously to the splashing of water onto its surface. In the preceding minute it was evident from the sounds that molten polymer was dripping into the water layer inside the tank. Splashes from this may have been the source of the water reaching the pool fire since the hole in the tank did not appear to reach fully down to the water level (though water did trickle from this area after the fire was extinguished and the material cooled with a CO₂ extinguisher). The subsequent fire behavior was substantially disturbed by the water reaching the pool fire so the test was terminated. The results indicated that the initial participation of the outer layers of the tank are not appreciably affected by an internal liquid but that subsequent opening of the wall is delayed. The outer layers were still able to contribute to the build-up of an interactive pool fire and a growing fire on both the bottom and the top of the tank. This supports the idea that the tank material contributed substantially to the growth of the pool fire in the Project B.3 fire test of this vehicle in which the tank contained 40 L of gasoline.

Front Fender Sound Insulation. Recall that this is a double layer of foamed polystyrene placed vertically at the rear surface of each front fender well. The concern here is not its heat release rate, etc. but specifically whether it could provide a fire path from the bottom of the vehicle up to (and through) a polyethylene cable feed-through that opens into the side of the instrument panel. This feed-through carries a cable bundle through two successive sheet metal walls, a few centimeters apart. As described earlier, this item was tested in its normal context using the vehicle section that encompasses the forward bulkhead and the instrument panel. The ring burner was used at its normal 7 kW level; it was mounted 4 cm to 5 cm below the lower edge of the test item. The test was videotaped.

The foam at the height of the feed through ignited within ten seconds and burned vigorously for nearly two minutes; only at the end of this interval did it tend to disintegrate and fall to ground level in flaming chunks. Post-test inspection showed that the polyethylene feed-through was largely intact; only its outermost flange (passing through the outer steel wall) was missing. The elastomer foam that sealed the space around the cable bundle within the feed-through was charred on its outer end. There was no indication of any opening into the instrument panel space as a result of the burning of the fender insulation material. A key protective feature in this configuration may have been the existence of the two steel walls; the flames did not get much past the outer wall to attack the feed through.

Instrument Panel Assembly. The same section of a vehicle was used in the following test. Recall that it included most of the major components (HVAC unit, ducts, etc.) normally attached on the interior of the forward bulkhead (see Fig. 11) and that the goal was to ascertain the rate of

development of a fire in these components (as an assembly) when the fire enters through the two designed-in holes in the bulkhead (one for the AC coolant tubes and one for the heater hoses). Also recall that the ignition source was unique here, being an enclosure on the outer side of the bulkhead which allowed flame impingement in the area of the two holes along with the application of a slight positive pressure which could drive flame gases through the holes. In an essentially vertical wall such as this, a fire plume will have only a weak tendency to pass partially through an opening; a pressure differential across the opening can have a major impact on the fire movement through the hole.

A hole which is completely sealed is, by definition, a barrier to the flow of hot gases (regardless of any pressure differential). The seal has to be slightly broken for gas flow to be initiated. Once initiated, the flow rate can increase as the hot gases further degrade and open-up the gasket material intended to provide the seal. In principle, the initial break in the seal could be produced by heat application on its exterior side. This will be most likely to happen if the gasket is thermoplastic in nature. In the case of a post-crash vehicle, of course, the seal may have also been lost as a result of the crash impact.

In the vehicle tested in Project B.3 (full scale fire), there were indications that the seals on these two holes were compromised by the crash to which the vehicle had been subjected prior to its being burned; hot gases did come through these holes during that burn [2]. Here an attempt was made to approximately reproduce this situation. All of the materials used here were undistorted by any impact so that, if they were mounted fully in place, a gas-tight seal would have been achieved since the gaskets were made of a thick foam rubber (unidentified). The mounting bolts were loosened and the HVAC unit was displaced slightly toward the passenger compartment so that some leakage through the holes was likely, between the bulkhead surface and the outer surface of the gasket. (The inaccessibility of the gasket surroundings - they were on the instrument panel side of the bulkhead - made the leakage path impossible to quantify.) The results of the test are thus only indicative of subsequent fire development in the presence of a pre-existing leak. Since the early fire development rate probably depends on the leak rate, the results here are not general.

Thermocouples (bare junction, chromel/alumel made from 0.013 cm diameter wire) were embedded in the gaskets around each hole. The gaskets themselves were approximately rectangular. Each had one thermocouple in each of the two upper corner regions of the rectangle (above the top edge of the hole). Each hole also had one free-floating thermocouple placed 2.5 cm above the top of the gasket, on the vertical axis of the hole. No weight or heat flux measurements were made in this test.

Fig. 26 shows the heat release rate results; note the ordinate scale. The igniter box pressure proved initially difficult to regulate and rose as high as 8 Pa in the first minute; after this it was maintained at 3 Pa throughout the remainder of the test. As was mentioned previously, 3 Pa was the peak level seen during the full-scale test fire with this vehicle in Project B.3. Smoke emerged from several locations on the passenger compartment side of the bulkhead within 30 s of burner

ignition. All locations were remote from the holes in the bulkhead, suggesting extensive channeling of the smoke. The thermocouples indicated that the temperature in the gaskets began to rise about 100 s after burner ignition; the thermocouple signal in the upper left-hand corner of the HVAC coolant inlet hole (as viewed from the passenger compartment side of the bulkhead) rose at several times the rate of that from all the others. This suggests that the principal hot gas passage was in this neighborhood, though the temperature here hit a plateau around 100 °C for 100 s or so before abruptly shooting upward, implying definite flame arrival there, at 300 s after ignition.

By two minutes after burner ignition, the principal emergence point for smoke was the grill atop the air outlet in the center of the topper pad. The smoke from this source intensified rather abruptly around 4.5 min but the cause was not evident. Actual flames on the passenger compartment side of the bulkhead could first be seen at just under 4 min, just to the right (passenger's side) of the vehicle midline, at mid height. This soon proved to be a melt/drip fire somewhere in the middle region of the HVAC unit which was dropping flaming material onto the upper right portion of the "transmission hump" (covered by the sound insulator mat). This fire grew slowly downward on the mat, as additional flaming melt dropped onto it. At 5.5 min flames emerged from the grill in the center of the topper pad and this manifestation of what was probably the same fire grew rapidly. Smoke was soon gushing from all of the air vents on the instrument panel and flames were visible throughout the depth of the central portion of the assembly through the holes left by the missing HVAC controls unit. By the time of the heat release peak in Fig. 26, the fire was throughout the central portion of the instrument panel and had produced a comparatively small interactive pool fire on both sides (and the top) of the "transmission hump". The fire was terminated at this point. Note that essentially all of the fire plume, for the entire duration of the fire, went up and out through the open windshield frame.

Post-test inspection revealed that the gasket on the heater hose hole was charred on its outer surface but was intact (the thermocouple signals in this gasket never indicated temperatures above 150 °C). The gasket on the AC coolant line hole was largely missing. The results tend to confirm the efficacy of a non-thermoplastic gasket which is sealed and the vulnerability which follows if the seal is lost due to crash damage.

Front Passenger's Seat. Figure 12 shows a picture of the test item used here. The seat was salvaged from a vehicle subjected to a full-scale, rear-end fuel-fed fire in Project B.3. It suffered only slight damage before that test was terminated. It had suffered some mechanical distortion of the back supports in the preceding rear-end crash; this necessitated shimming the rear of the seat base to keep the seat back at a normal angle. The materials in the seat were not identified but are not believed to be in any way unusual except that the bottom of the seat cushion was protected by a sheet metal pan.

The seat was tested in the 500 kW hood facility. It was placed on top of a layer of cement fiberboard contained in a large pan. This assembly was atop the GSE scale noted above; there was no attempt to separately measure the weight of the seat and its melt/drip pool fire. The ring

igniter was used here at its usual 7 kW level. It was placed 14 cm above the fiberboard in a location where its plume would impinge on the lower rear section of one side of the seat back and partially on the lower rear area of the seat cushion pan cover. Two heat flux gages were used, both mounted horizontally. The first viewed the rear center of the seat back (from a distance of 5 cm) at the height of the arm. The second viewed the juncture of the seat back with the seat (from a distance of 5 cm) from the side away from the igniter.

The test results are shown in Fig. 27; again note the ordinate scale. Fire growth up the back of the seat was rapid, as would be expected for a foamed material having a low thermal inertia. Flames spread the full height of the seat by 1.5 min after burner ignition. Lateral spread on the seat back was also rapid so that, by the time the flame front reached the top of the seat back, it had also spread across the full width for about half the height. From this point on, the fire basically progressed from the back of the seat back to the front edge of the seat, after first breaking through the seat back, near its base, at 2.5 min. This breakthrough may have been partially assisted by a significant interactive pool fire at this time, resulting from "melting" foam and from numerous fallen, flaming segments of fabric and foam. Flame spread forward on the top of the seat cushion was rapid (from no burning to nearly full involvement in 45 s), presumably due both to the foamed material and a substantial radiative pre-heating effect from the fully-involved seat back.

The flux gages had been intended to read a radiative flux only but they proved to be close enough for some flame impingement. Inspection of the flux gage environment on the video tapes is not entirely unambiguous but it suggests that any time the flux was above 40 to 50 kW/m² the gage was immersed in flames (and thus was seeing convection plus radiation). At other times radiation alone reached 40 to 50 kW/m². There was a time period of 100 s to 150 s where the radiative fluxes appear to stay in this range; the generic ignition curve in Ref. 4 suggests that this would be quite sufficient to produce an ignitable condition in adjacent materials close enough to receive such flux levels.

Passenger Compartment Headliner. This is a molded, multi-layer structure that lines the top of the passenger compartment; no photo is available. The exposed surface is a thin layer of fabric (nylon); above this is a thicker layer of flexible foam (polyester-based polyurethane); above this is a still thicker layer of rigid foam (MDI/polyether-based polyurethane); above this is another thin fiber layer. The total structure is only roughly 4 mm to 5 mm thick. This part was large enough to allow it to be cut in half (transversely, across the width of the vehicle) and tested twice.

This item can be exposed in a vehicle fire to accumulating hot gases from any fire lower in the vehicle. Here this accumulating effect was assured by mounting the liner in an inverted pan, approximately 20 cm deep. The pan was essentially the size of half of the full headliner; in this sense it allowed hot gas accumulation at twice the rate that would occur in a vehicle. Aluminum foil was used to create a rough seal between the peripheral edge of the liner and the bottom edge of the inverted pan in order to minimize the passage of hot gases into the space above the headliner. Holes in the headliner (for seat belt anchors or dome lights, etc.) were also closed off

with aluminum foil for the same reason. The ignition source (which here was the only external source of accumulating hot gases) was a T-burner, 60 cm long placed so that its elongated row of flames impinged on the downward curved surface of either the front or rear end of the headliner (centered on the longitudinal axis of the vehicle). This burner configuration was chosen to provide a closer simulation (than one would get with the ring burner used elsewhere in this study) of the situation observed in the full-scale minivan front-end fire tests [2]. The burner was run at 6.6 kW from time zero onward. Six thermocouples (bare junction chromel/alumel made from 0.02 cm dia. wire) were inserted from the top into holes drilled through the liner so that their junctions were 2 mm to 3 mm below the bottom surface of the liner (closer to 10 mm below in the second test). The thermocouples were arrayed in two rows of three each, along lines parallel to the vehicle axis, 25 cm to either side. In the first test (using the rear half of the headliner), the first thermocouples were 33 cm from the igniter; the next sets came at 30 cm intervals. In the second test the arrangement was similar except that the first set of thermocouples was 30 cm from the igniter. One heat flux gage was used in each test. It looked vertically from an initial distance of 5 cm below the bottom surface of the liner. It was located at least 45 cm from the igniter. The headliner drooped onto the gage in the first test, giving an erroneous flux reading; this was prevented in the second test by using a rod to support the liner. No weight measurements were made. A Durock surface was located about one meter below the liner; no significant interactive pool fires developed.

The results of the first test (rear section of the liner) are shown in Fig. 28a. The heat release from the liner was minimal. Since this test was done in the 500 kW hood (because of the physical size of the test item), the small heat release which did occur (beyond the igniter level) is not accurately measurable. Immediately upon ignition of the burner a wave of discoloration spread smoothly outward along much of the central width of the liner. This slowed as it progressed, finally reaching about halfway between the middle and farthest pair of thermocouples (nearly 80 cm from the burner). Smoke began to rapidly accumulate in the inverted pan space as the front slowed and the area it had encompassed grew more darkly discolored. The thermocouple records show that the front was thermal in nature but did not represent ignition; the temperatures behind the front were too low for this. The flexible foam layer in one laterally outward section roughly halfway between the igniter and the farthest extent of the initial front began to break loose and droop erratically downward at about 1.5 min; as it did so it ignited. This loosening/drooping/burning process in the flexible foam layer then spread directly away from the igniter for the next 30 s, reaching the outermost thermocouple on this side before stopping. As it stopped, the same process began in a corresponding area on the other side of the longitudinal centerline, again reaching about the same distance in roughly the same time before halting (and extinguishing). Neither spread process moved in toward the centerline where the heat flux gage was located and neither encompassed the thermocouples more than tangentially (one thermocouple in the pair closest to the igniter did exceed 600 °C for about 50 s; the other thermocouples reached roughly steady levels of around 175 °C to 225 °C). In the remainder of the test little else happened except for erratic localized spread on the flexible foam layer adjacent to the igniter. The rigid foam layer turned black but remained intact (except for drooping onto the flux gage) and did not appear to spread any flames on its surface.

Fig. 28b shows the results of the second test (forward half of the liner). Here, for unclear reasons, there was some oscillatory coupling between the igniter and the liner, causing the igniter flame to pulsate every few seconds. It did not appear to have any serious consequences on the overall behavior. Nevertheless, that behavior did differ somewhat from that seen in the first test. The initial spreading discoloration front did not reach as far before stopping (10 cm to 15 cm less far). At about 2 min after ignition the flexible foam layer began again to break loose in an area laterally outside that monitored by the thermocouples but, this time, it did not ignite and thus the process halted temporarily. If it occurred on the opposite side it was obscured by smoke. At about 4 min flames began to spread away from one end of the igniter, laterally along the bottom edge of the liner. By 6 min this small flame had reached the corner of the liner on that side and began to grow, reaching further in (and higher) on the liner surface, evidently burning off the flexible foam layer. It ignited the drooped down portion of the flexible foam layer and started a general surge in fire growth throughout roughly 1/4 (or less) of the liner over the next minute; this is the source of the spike in heat release rate seen in Fig. 28b. The later portions of this appeared to involve some flaming of the rigid foam layer. Beyond this time, little else of note happened.

The heat flux data in Fig 28b are not affected by drooping of the headliner. However, it is likely that the source of the heat flux is the area of the liner heated by the igniter. One of the thermocouples around this gage location read 400 °C to 600 °C for much of the test time. Others were in the 200 °C to 300 °C range. These were gas temperatures; if the charred liner surface was heated by these gases to 300 °C to 400 °C over the area viewed by the gage, it would account for the flux level seen. (Recall that a similar effect was seen with the hood liner.) Unfortunately, the gage did not view any flame spread processes.

The relatively minimal display of fire growth here contrasts with what seemed to be more vigorous growth in the full scale tests of the vehicle in Project B.3. The source of these apparent differences is not certain. However, it should be noted that the headliner was not directly viewed in the Project B.3 tests. What appeared there (in laterally oriented cameras) to be vigorous flame propagation in the upper layer of smoke in the vehicle could have originated in flammable gases generated by burning objects lower in the passenger compartment

5) Discussion

The vehicle parts tested here represent a very diverse variety of shapes, sizes, materials and structures. Not surprisingly, the fire behavior seen was equally varied and influenced by a host of differing phenomena.

Many of the thermoplastic parts showed a marked tendency to form a melt/drip pool fire. This represented a simple extension of the area available for burning of the fuel if the pool fire plume was too short to reach the object. However, if the pool fire, abetted by a low polymer melt viscosity and a sufficient polymer mass, grew to the point where its plume began to overlap the object, a more rapid, interactive fire growth process followed, leading to an enhanced rate of heat release. This enhancement appeared to be greatest in cases where the pool fire plume was able to

accelerate the rate of fire spread over the object since the pool fire thereby accelerated its own growth. The battery presented such a case in which the enhancement in peak heat release rate exceeded a factor of four.

The above processes were made more difficult to unravel when the part underwent physical collapse onto the pool surface (as opposed to a simple meltdown to form a liquid pool). This appeared to be more likely with thin-walled parts comprised of a higher melt viscosity resin or thin-walled thermoplastic parts of large dimensions (even with a low melt viscosity resin). Of course, this potential collapse behavior can be highly affected by the presence or absence of a thermally resistant internal structure to the part (e.g., metallic components).

Other parts, composed of thermoset resins or having a large fiber content, retained their shape and yielded no significant melt/drip behavior. The parts of this nature examined here were large in physical extent compared to the area struck by the igniter plume; thus their burning behavior was dominated by flame spread processes. Two of the parts, the hood liner and the head liner, whose low density would make them especially vulnerable to rapid flame spread, seemed to limit this threat by having low heat release rate components on their exposed surfaces. (The hood liner was held in place by thermoplastic clips which allowed the more flammable inner materials to become exposed ultimately and burn.)

All of the parts, when burning, were seen to be a threat to their surroundings (i.e., other flammable parts); this threat was greatest above the part since this was where its fire plume went. Contact with a fire plume that persists for several tens of seconds is likely to ignite the contacted part, if it is a typical engine compartment, polymer-based component. Thermoplastic parts are a threat to objects below them as well, via flaming melt/drip behavior. This may be strongly influenced by the geometry of the surfaces onto which a polymer melt may fall; pooling of the flaming melt on a lower part may exacerbate the hazard if this allows an extended burn time that increases the probability of ignition of this adjacent part (pooling may become irrelevant if the melt/drip process extends in time past the ignition time of the adjacent part). Radiation to the sides is a lesser threat except when the radiating flame volume reaches something of the order of 20 cm to 30 cm in diameter. However, even radiative heat fluxes too low to directly cause ignition can accelerate subsequent flame spread through pre-heating or can cause addition to an existing pool fire through additional melting of surrounding parts.

The instrument panel assembly is an example of fire growth in an array of vulnerable thermoplastic parts. The interaction of components is essentially assured in such arrays. Here the downward progression through the array via flaming melt/drip behavior appeared to be slower than the upward spread. Significant portions of an engine compartment can approach the spatial density of flammable components seen in the instrument panel assembly; thus similar behavior might be expected. In other words, many automotive components may not find themselves burning in isolation (as in nearly all tests here) but rather as an element of a complex spatial array (possibly made more compact and more complex as a result of a crash). This suggests that, if fire growth rate is to be substantially slowed, flammability improvements will be needed not in one or

two large components but in most, if not all. It also suggests that the most meaningful assessment of the flammability improvement in an individual part comes in a test where the heat inputs from surrounding burning objects are somehow simulated. Since we currently have no procedure for predicting the behavior of an array of parts from the behavior of individual components, the ultimate proof of improvement in the array must come from empirical testing of actual vehicles.

Continuing with this theme, we note that the results here, even for isolated components, are highly specific to the test conditions. The fire growth process, the heat release rate and the heat fluxes to the surroundings all would be expected to vary if the igniter location or size was changed; similarly, changes in part orientation and, especially, changes in the proximity of a potential pool surface (for thermoplastic parts) would be expected to alter the results. There is as yet no quantitative means for estimating the magnitude of the alterations. The results here for a battery burned in three different configurations suggest that, at least for thermoplastic parts, the alterations can be large when an interactive pool fire is involved.

Other parts of Project B.10 (at General Motors and at Factory Mutual Research Corporation) have provided extensive characterization data on the polymers in the parts studied here. The mass of polymer in each part is one of the most elementary characterizations provided [GM results and Ref. 5]. Figure 29a shows a plot of the peak value in net heat release rate from a part (igniter contribution subtracted out) versus this polymer mass (estimated for the batteries); see also the tabulation in Table 3. For an order of magnitude range in polymer mass these (very limited) data suggest that this parameter overrides all other considerations in determining the peak heat release rate. This is a risky conclusion given the fact that there are only two points at the right end of the graph (though they come from two very different parts, the seat and the fuel tank). In any event, this is not really helpful toward the goal of learning how to slow the growth of post-crash fires in motor vehicles; drastic reduction in polymer mass is not a realistic option. Fig. 29b shows that when we close in on the mass range of many of the individual parts found in a vehicle, mass alone is an essentially useless predictor of heat release rate. (The varying heat release results from the batteries presaged this conclusion.)

The available characterization of the polymeric constituents of the parts studied here includes more sophisticated measures of their flammability properties such as ignitability, flame spread and heat release rate behavior, expressed in the form of various indices [Ref. 5]. These are all useful in assessing and seeking to improve the flammability behavior of a particular part. For example, the flammability behavior of a battery can undoubtedly be improved by use of a polymer resin which is demonstrated to have a much reduced rate of heat release. However, lacking a predictive basis for assessing the quantitative role of this one parameter in overall fire performance, we cannot say how much such a change would decrease the peak heat release rate from a burning battery. Furthermore, we are lacking even clear-cut qualitative guidelines as to how alterations in some of the many geometric and structural parameters of a vehicle component would impact its flammability. Those parameters varied widely in the present tests precluding any simple correlation of the results here with the measured properties in the other segments of Project B.10.

Fire science does have a good handle on the role of material flammability parameters in flame spread and heat release rate processes for simple (e.g., flat wall) geometries. The qualitative knowledge derived from those studies, combined with empirical testing of improved materials in standardized parts, will point the direction for overall improvements in vehicle fire behavior.

6) Next Directions

The results here have provided a broad view of the types of flammability behavior which vehicle components can exhibit. This study has not been exhaustive as to the potential range of flammability behavior; there will continue to be a need to examine a limited number of other parts, from other vehicles, both to search for new modes of behavior and to shed light on the planned full-scale fire tests. However, there is a need now to begin to look for ways to alter the flammability behavior of vehicle components in such a way as to slow the rate of fire growth and thus, potentially, to gain time for rescue of crash victims. The most promising way to accomplish this for the wide variety of polymeric parts in modern vehicles appears to be by the addition of flame retardants to the resins; other additives (e.g., reinforcing fibers and melt viscosity modifiers) may be worth exploring, as well. A strong constraint on such modifications is the need to retain acceptable processing parameters, physical properties and cost.

Component construction and shape has been shown here to have a strong impact on fire behavior. These parameters vary widely, as dictated by the functional needs of the part. It is unrealistic (and too limiting) to attempt, at this stage, to explore the impact of such modifications as flame retardant addition in the context of a complete set of parts from, for example, the engine compartment of a specific vehicle. Before the considerable expense of such testing is justifiable, it is necessary to explore resin additive effects in one or two "generic" parts which capture the complexities seen in this study (such as varied wall thickness, presence or absence of inert internal components, differing contributions from flame spread vs. mass burning, sensitivity to orientation, etc.). A viable additive system must be demonstrated to be effective in spite of these complexities. It should also be effective in assemblages of such generic components which roughly mimic the nearly random juxtapositioning of polymeric components to be found across the fleet of modern vehicles, especially in the engine compartment. Additive packages which can survive this sort of assessment are ready to compete with alternatives approaches such as fire suppression systems in vehicles.

7) References

- 1) Maxwell, J., *Plastics in the Automotive Industry*, Woodhead Publishing Ltd., Cambridge, England, 1994, Chapter 1
- 2) Jensen, J., Santrock, J., Strom, K. and LeMieux, D., "Evaluation of Motor Vehicle Fire Initiation and Propagation, Part I: Vehicle Crash and Fire Propagation Test Program," report in preparation, February, 1998
- 3) Babrauskas, V. and Grayson, S. (eds.), *Heat Release in Fires*, Elsevier Applied Science, London, 1992
- 4) Ohlemiller, T. and Cleary, T., "Motor Vehicle Fire Threat from Flammable Liquid Spills on a Road Surface," to be published as a NIST Interim Report.
- 5) Tewarson, A., "A Study of the Flammability of Plastics in Vehicle Components and Parts," Factory Mutual Research Corporation Report FMRC J.I. OB1R7.RC, August, 1997

8) Acknowledgement

The authors would like to acknowledge the helpful assistance of Ismat Abu-Isa and Douglas LaDue of General Motors Corp.

TABLE 1 COMPOSITION AND MASS OF SELECTED VEHICLE PARTS

Component Number	Part Description	Material Form	Polymer Identification	Percent Inorganic Filler	Mass kg
743	headliner, backing - top layer, structural support	fiber	polyethylene terephthalate (PET)	38%	
	headliner, high density foam - layer 3	foam	polyether urethane (PPO + MDI)	1%	
	headliner, low density foam - layer 2	foam	polyester urethane with Surlyn film	1%	
	headliner, fabric - exposed surface, bottom layer	fabric	nylon 6	1%	
	headliner, center - structural support	fiber	PET Binder on glass		
654	Whole system				2.60
	instrument panel, foam - between structure and cover	foam	polyether urethane (PPO + MDI)	1%	
	instrument panel, cover - exposed surface	elastomer	polyvinylchloride (PVC)	8%	
	instrument panel, structure	thermoplastic	polycarbonate (PC)	0%	
	Whole system				3.61
611	instrument panel shelf, main panel	thermoplastic	PC	0%	
	instrument panel shelf, foam - small seals	foam	polyether urethane	37%	
	Whole system				2.75
	resonator, structure	thermoplastic	polypropylene (PP)	20%	0.71
	resonator, intake tube	elastomer	ethylene propylene diene monomer (EPDM) elastomer	2%	0.29
256	resonator, effluent tube	elastomer	EPDM	2%	0.14
	Whole system				1.14
	air ducts, small ducts	thermoplastic	polyethylene (PE)	0%	
	air ducts, large ducts	thermoplastic	PP	19%	
	Whole system				4.26

Component Number	Part Description	Material Form	Polymer Identification	Percent Inorganic Filler	Mass kg
736	brake fluid reservoir, reservoir	thermoplastic	PP	0%	0.67
	brake fluid reservoir, cap	thermoplastic	PP	1%	0.07
	Whole system				
3008	wire harness tube,	thermoplastic	PE	0%	0.07
967	windshield wiper tray, structure	SMC	sheet moulding compound (SMC)	47%	3.40
868	fender insulation, low density foam - sound reduction	foam	polystyrene (PS)	33%	
	fender insulation, high density foam - sound reduction	foam	PS	39%	
	Whole system				0.11
870	hood liner, insulation (back)	material	PET, cellulose and epoxy	2%	
	hood liner, face	material	PET	1%	
	Whole system				1.00
208	wheel well cover, fuel tank shield	thermoplastic	PP	2%	0.56
676	HVAC unit, door - foam covering	foam		0%	0.29
	HVAC unit, door - for thermostat	foam	PVC	16%	0.08
	HVAC unit, door - structure	thermoplastic	nylon 66	37%	
	HVAC unit, door - rubber seal	elastomer	thermoplastic polyolefin (TPR)	11%	
	Whole system				0.23
	HVAC unit, door - structure	thermoplastic	nylon 66	39%	
	HVAC unit, door - rubber seal	elastomer	TPR	14%	
	Whole system				0.11
	HVAC unit, door - structure	thermoplastic	nylon 66	39%	
	HVAC unit, door - rubber seal	elastomer	TPR	12%	
	Whole system				0.10
	HVAC unit, cover	thermoplastic	PP	36%	0.13

Component Number	Part Description	Material Form	Polymer Identification	Percent Inorganic Filler	Mass kg
	HVAC unit seal, foam - heating coil entrance	foam	acrylonitrile-butadiene rubber and PVC blend	17%	
	HVAC unit seal, backing - heating coil entrance	elastomer	ethylene vinyl acetate	17%	
	Whole system				
	HVAC unit, top main housing - contains coils, doors and fan		PP		0.05
	HVAC unit, bottom main housing - contains coils, doors and fan		PP		0.87
	HVAC unit, fan top cover	thermoplastic			1.61
	HVAC unit, fan bottom cover	thermoplastic			0.29
	HVAC unit, cover - for directional control	thermoplastic		36%	0.11
	HVAC unit, deflector - for air flow	thermoplastic			
	HVAC unit, actuator - casing	thermoplastic			0.09
	HVAC unit, housing	thermoplastic		30%	0.15
	HVAC unit, Seals - both large and small	foam	acrylonitrile-butadiene rubber and PVC blend	35%	0.25
	HVAC unit, seal	foam		18%	0.04
	HVAC unit, seal	foam			0.00
	HVAC unit, seal	foam			0.02
	HVAC unit, defogger tube	foam	TPR		0.01
				11%	0.03
201	fuel tank, tank	thermoplastics	PE	0%	
	fuel tank, hoses	thermoplastics	nylon 12	0%	
	fuel tank, threads/seal - for fuel pump	thermoplastics	PE	0%	
	Whole system	thermoplastics			8.48
798	headlight, lens	thermoplastics	PC	0%	
	headlight, backing	thermoplastics	PC	0%	
	headlight, retainer	thermoplastics	polyacetal (polyoxymethylene)	0%	

Component Number	Part Description	Material Form	Polymer Identification	Percent Inorganic Filler	Mass kg
	headlight, bulb support structure - halogen	thermoplastics	polyimide	30%	
	headlight, leveling mechanism	thermoplastics	PC	0%	
	Whole system	thermoplastics			1.70
222	battery casing, top	thermoplastics	PE/PP blend	0%	
	battery casing, sides & bottom	thermoplastics	PE/PP blend	0%	
	Whole system	thermoplastics			17.30
230	battery cover,	thermoplastics	PP	0%	0.36

Table 2. Measured Flame Spread Rates on Wiper Tray

Tray Half	Location	Flame Spread Rate (cm/s)
Driver's Side	Outer Lip of Tray, Toward Vehicle Centerline	0.28
"	Outer Lip of Tray, Toward Driver's Side of Vehicle	0.14
"	Bottom Interior of Tray, To Driver's Side of Vehicle	0.34
Passenger's Side	Outer Lip of Tray, Toward Passenger's Side of Vehicle	0.21 (From Video)

Table 3. Peak Net Heat Release Rate from Vehicle Parts

Vehicle Part	Polymer Mass in Part (kg)	Peak Net Heat Release Rate (kW)
Isolated Battery	ca. 1.3	21
Battery plus Battery Cover	ca. 2	53
Battery in Heated Box	ca. 1.3	88
Air Intake Resonator	1.14	85
Headlamp Assembly	1.7	23
Brake Master Cylinder	N. A.	10
Wiper Tray (Driver's Side)	1.7	53
Wiper Tray (Passenger's Side)	1.7	58
Hood Liner (Driver's Side)	0.5	25
Hood Liner (Passenger's Side)	0.5	16
Rear Wheel Well Liner	0.56	85
Fuel Tank (Empty)	8.48	500
Front Passenger's Seat	8	540

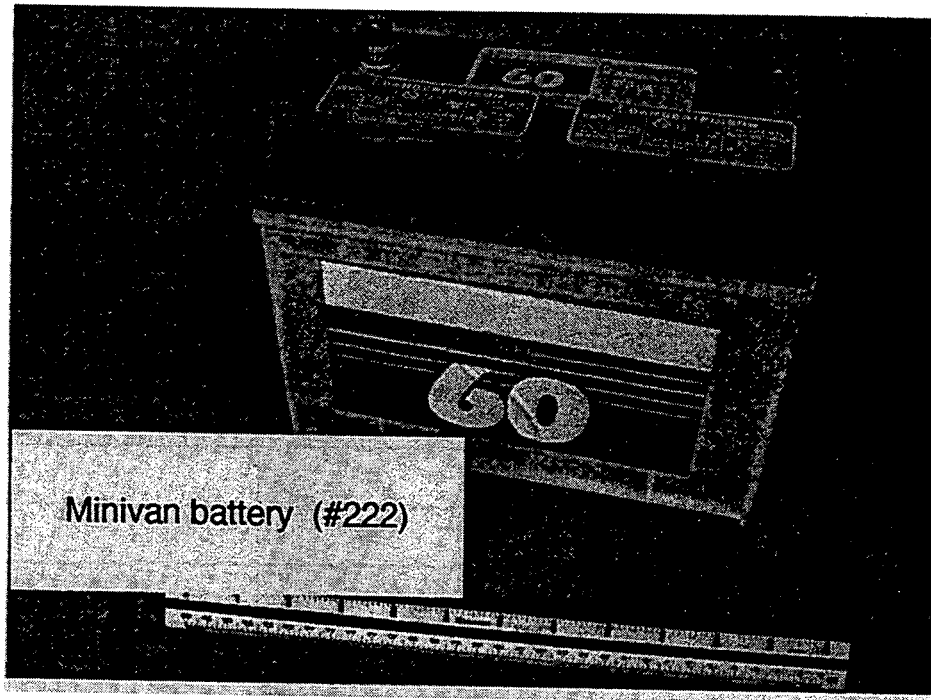

Figure 1. Minivan battery with 30 cm (12 in) length reference.

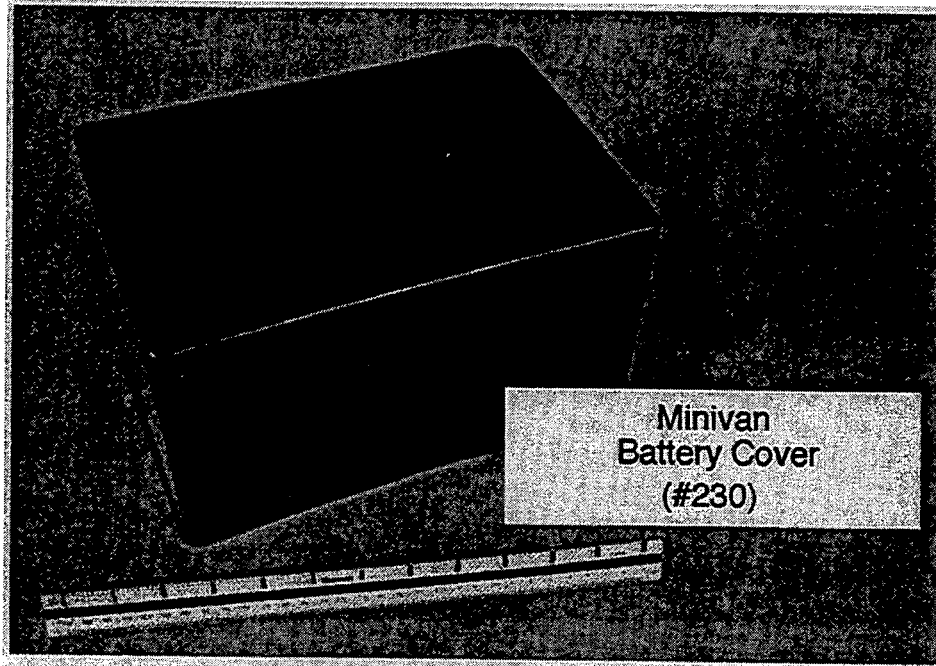

Figure 2. Minivan battery cover.

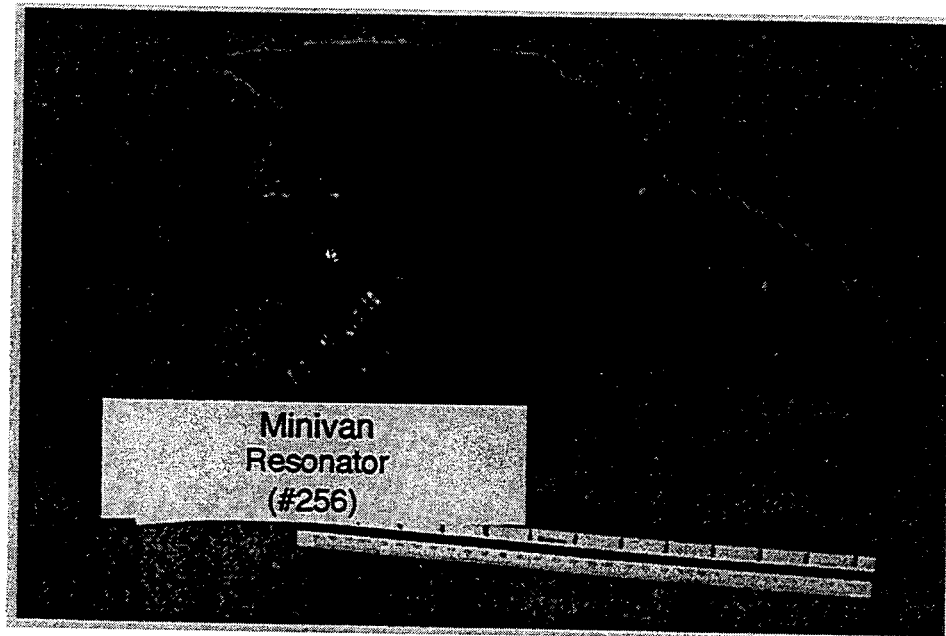

Figure 3. Side view of intake resonator plus ducts.

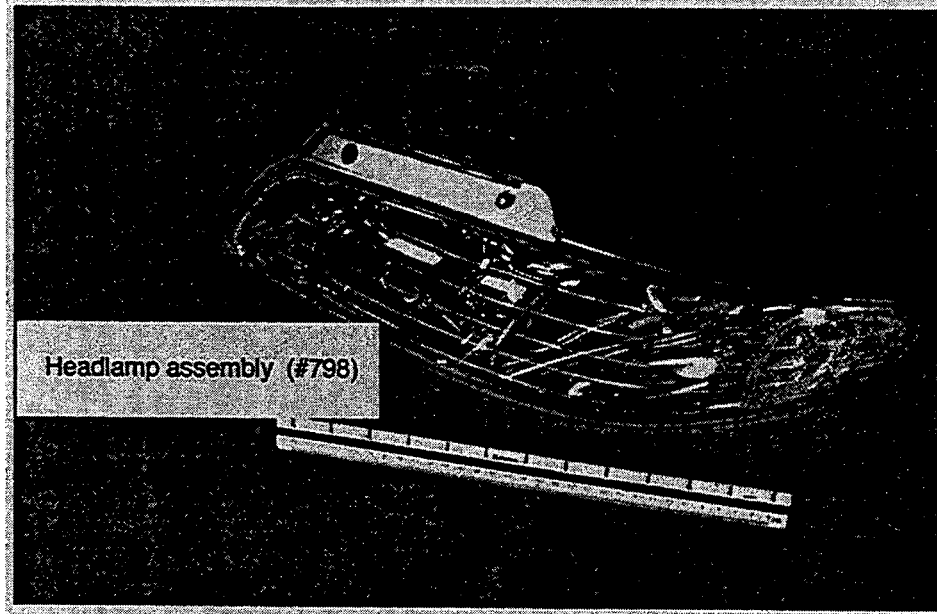

Figure 4. Minivan headlamp assembly.

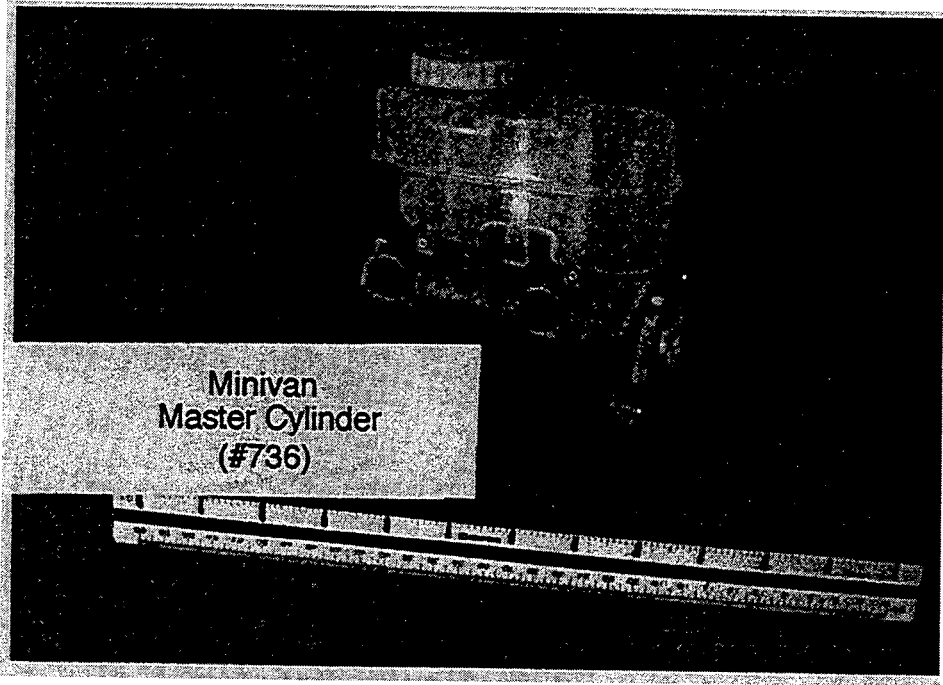

Figure 5. Minivan brake master cylinder and brake fluid reservoir.

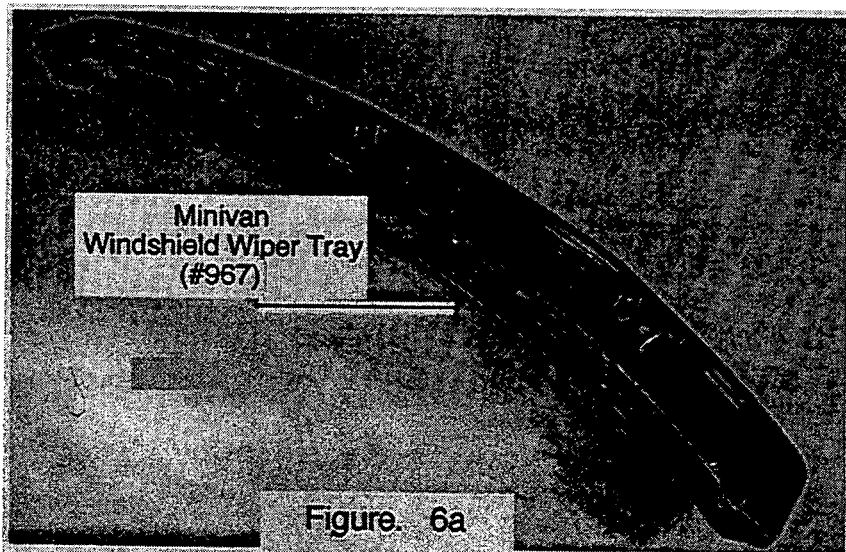

Figure. 6a

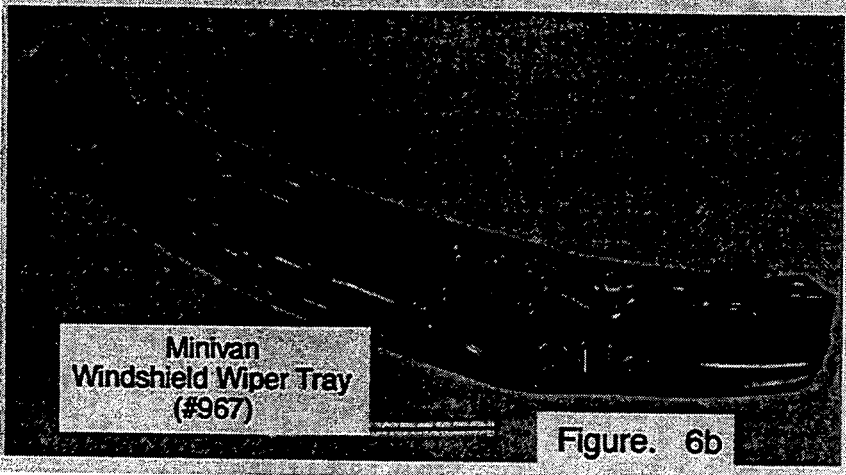

Figure. 6b

Figure 6. (a) Top view of minivan windshield wiper tray
(b) Bottom view of minivan windshield wiper tray

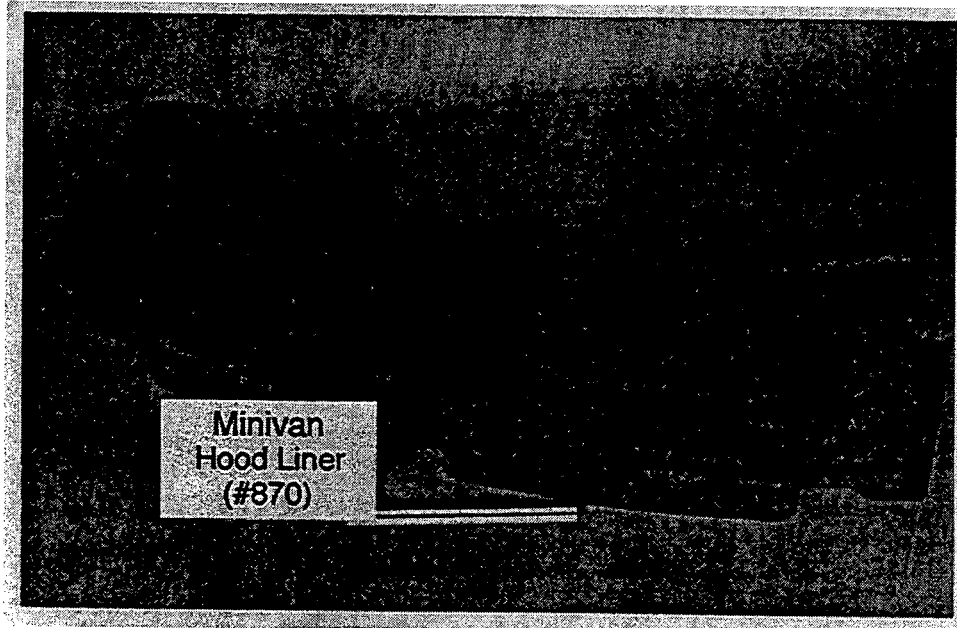

Figure 7. Minivan hood liner as seen from side facing hood.



Figure 8. Minivan rear wheel well liner.

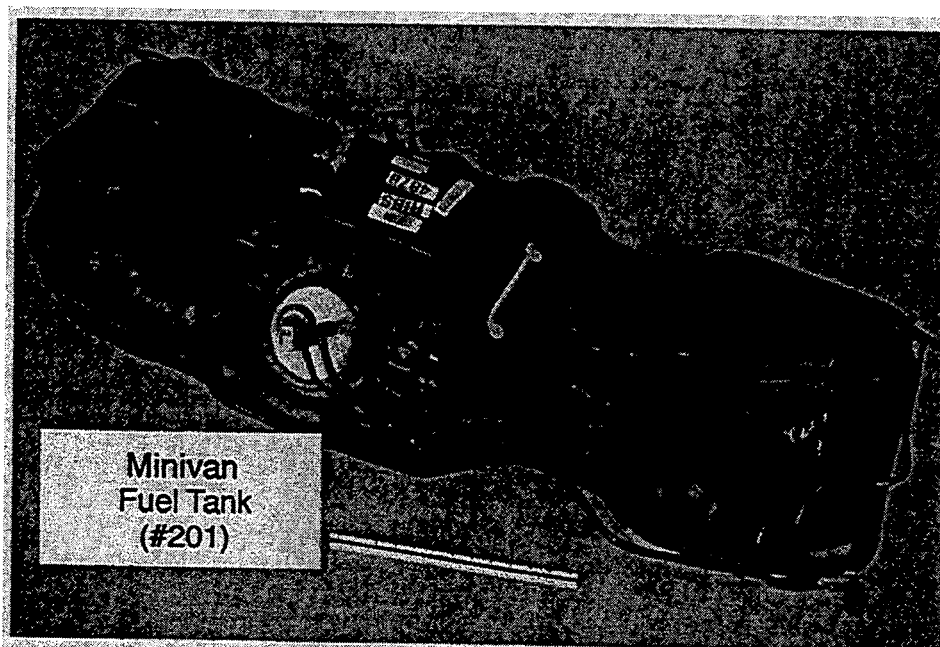

Figure 9. Top view of minivan fuel tank (side facing bottom of surface of vehicle).

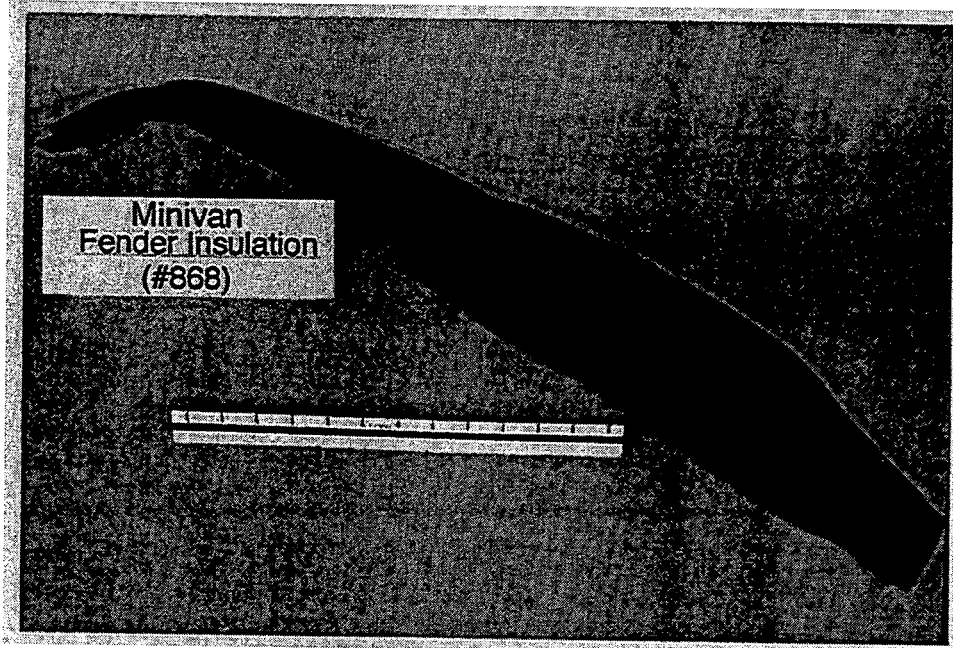

Figure 10. Front fender well sound insulation.

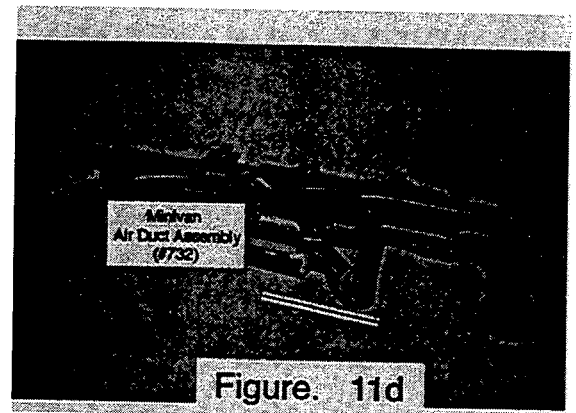
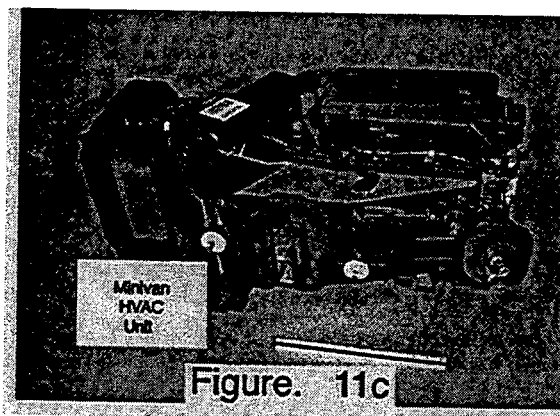
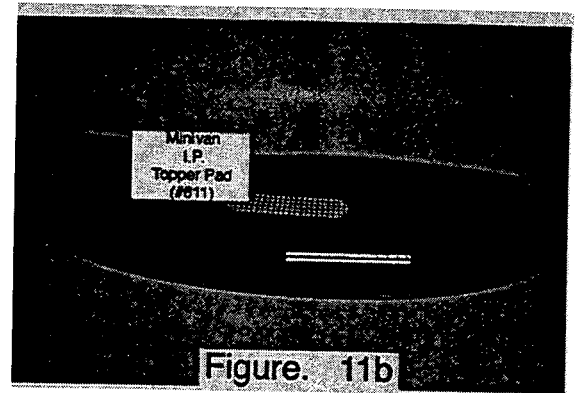
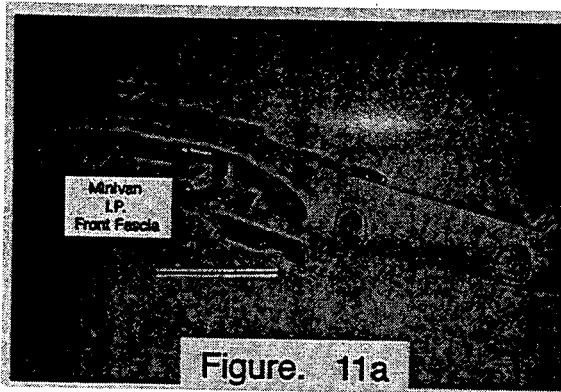

Figure 11. Components of the instrument panel assembly as tested (not shown, but included, was the interior bulkhead liner).

- a) front fascia of instrument panel
- b) topper pad of instrument panel
- c) HVAC unit; rear view showing AC coolant inlet (center) and heater fluid inlet tubes (right); note foam gaskets to seal holes in bulkhead.
- d) air duct assembly

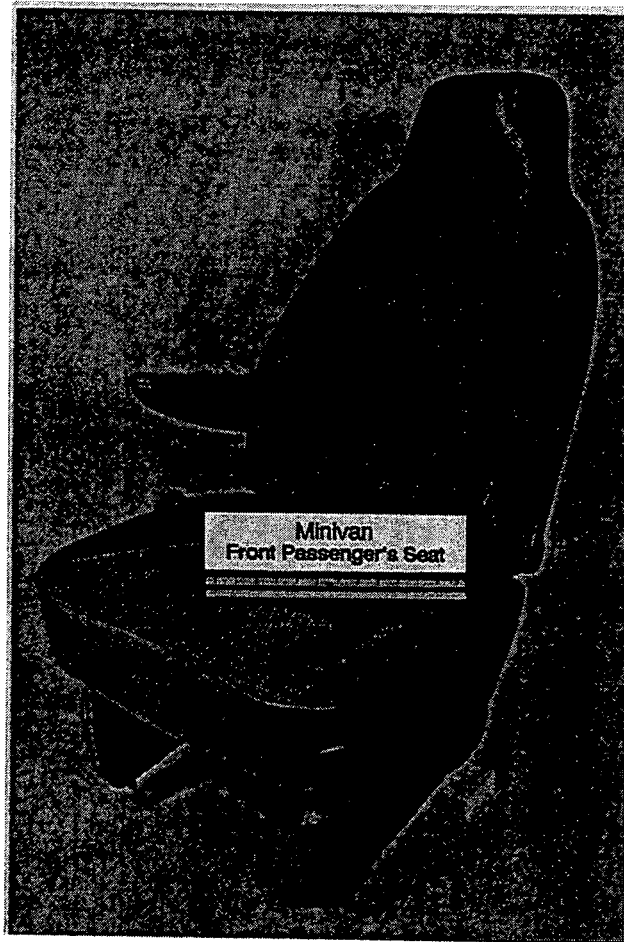

Figure 12. Minivan front passenger seat.

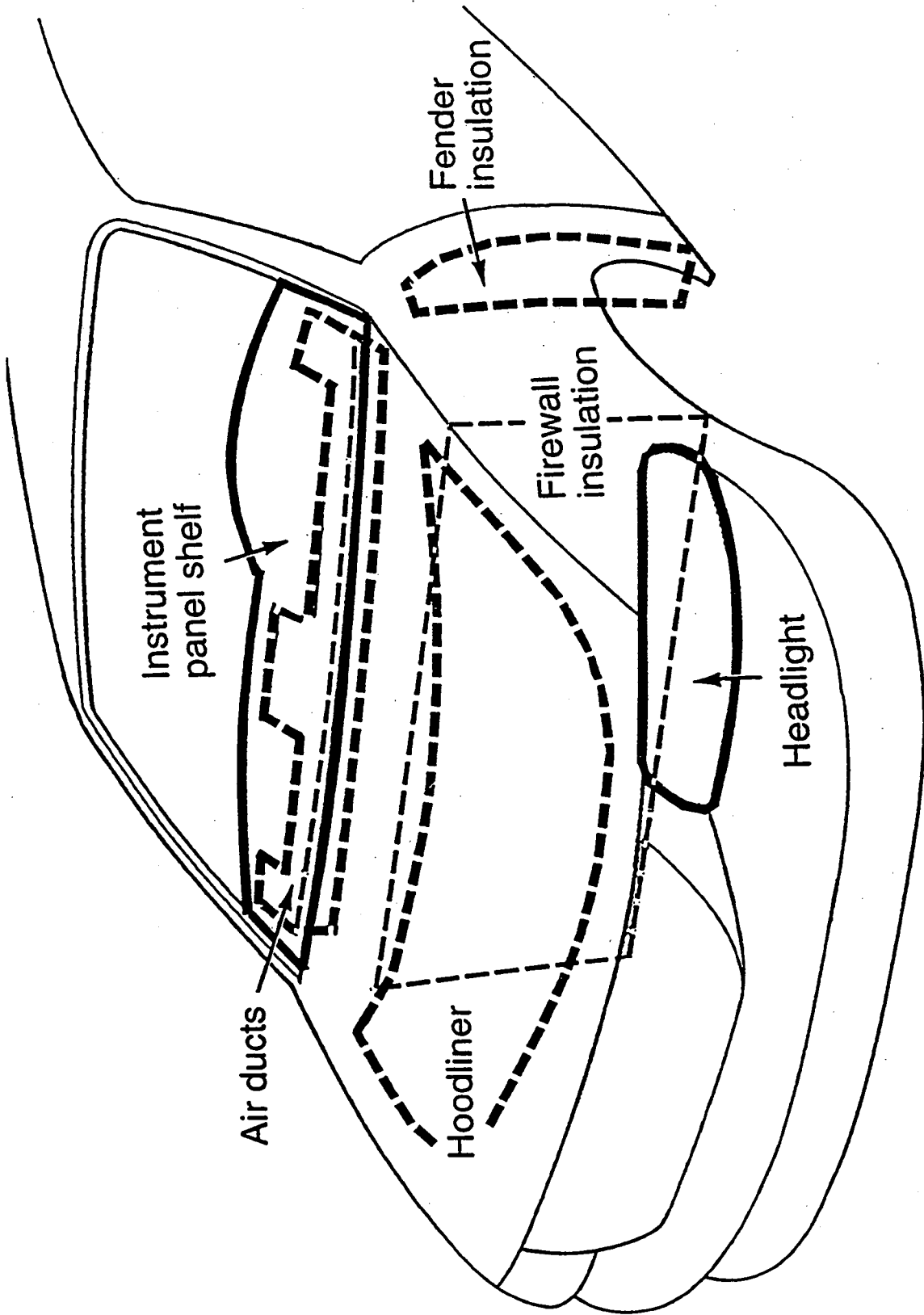

Figure 13a. Front view schematic showing parts locations in the minivan

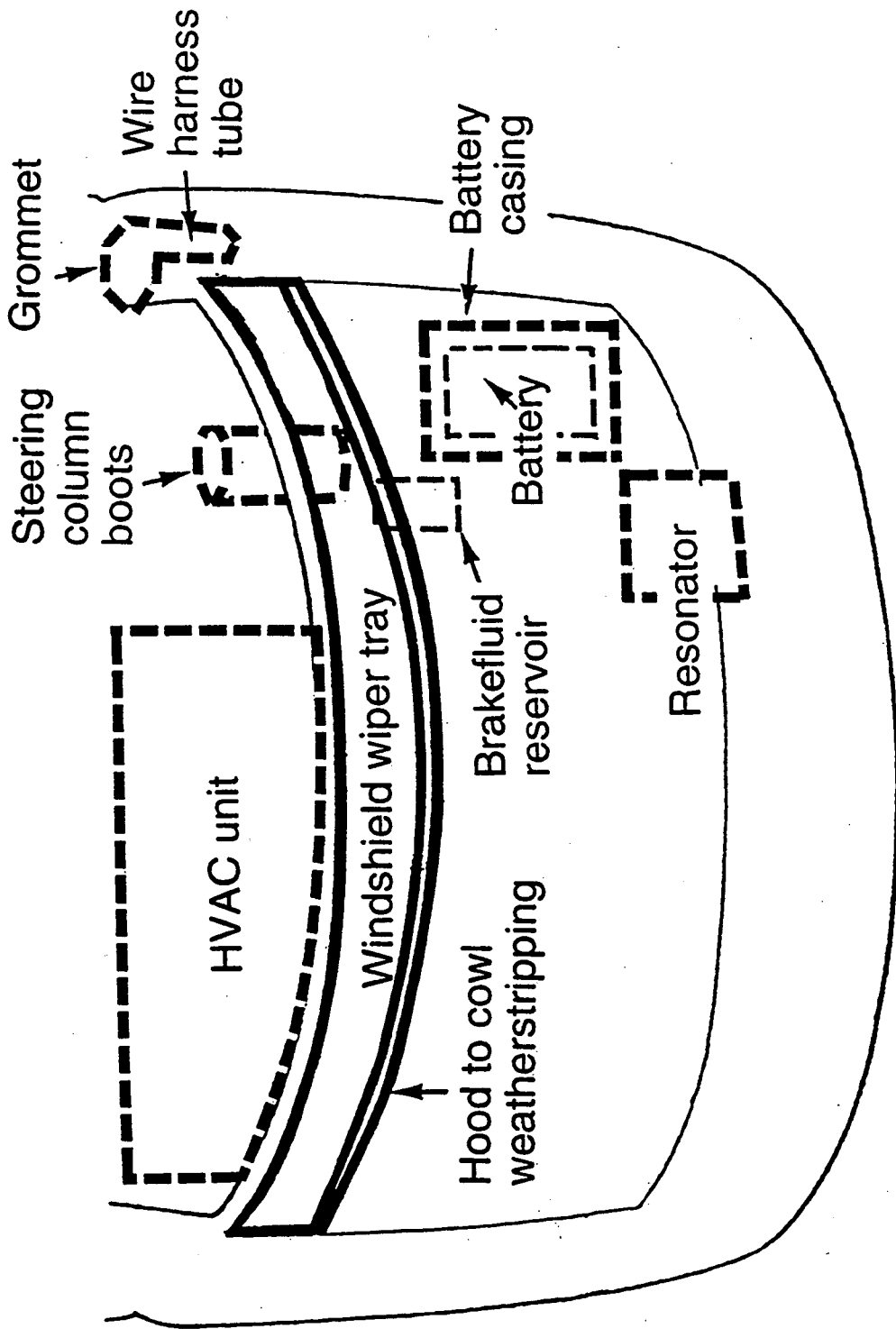

Figure 13b. Schematic top view of the minivan engine compartment showing locations of parts

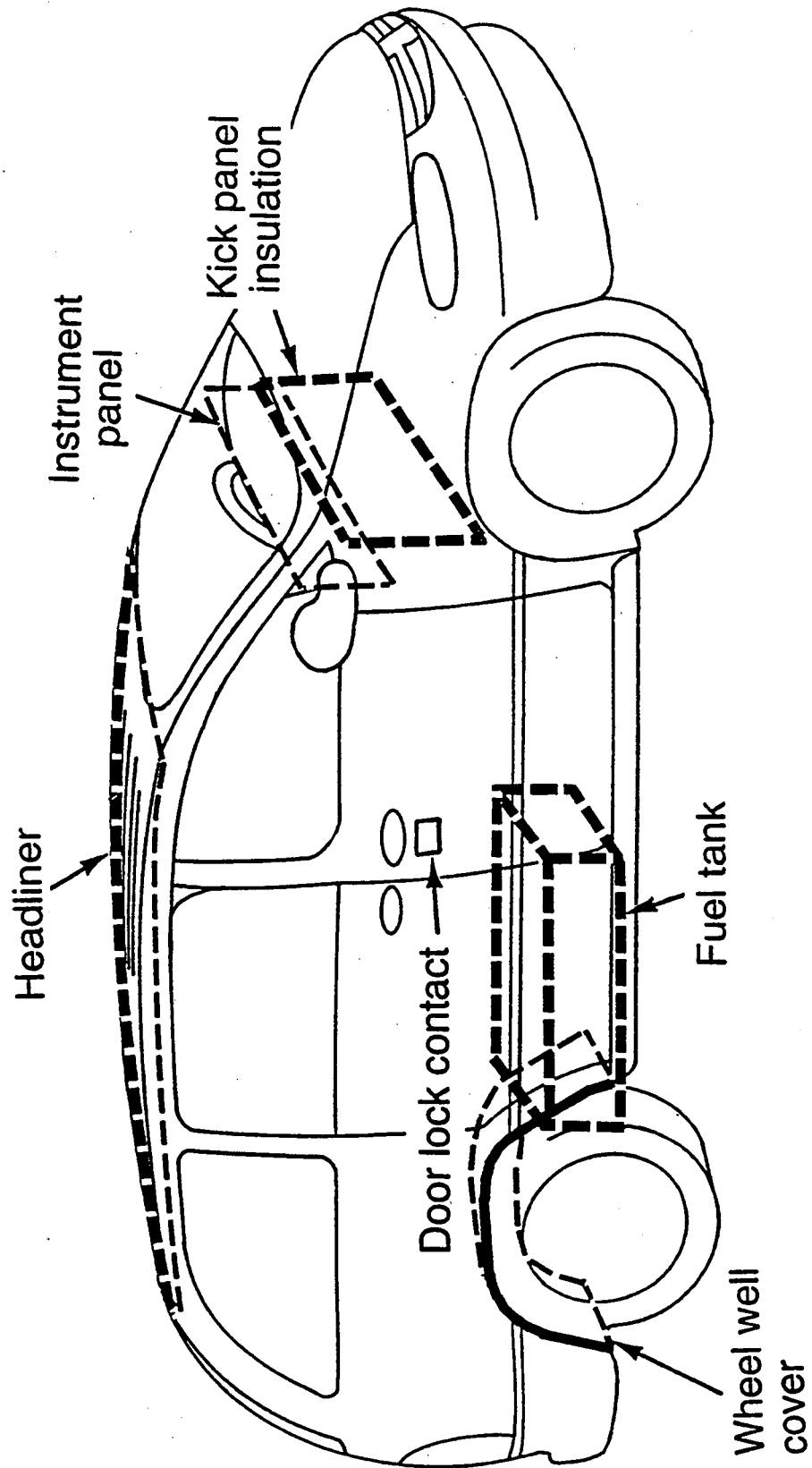
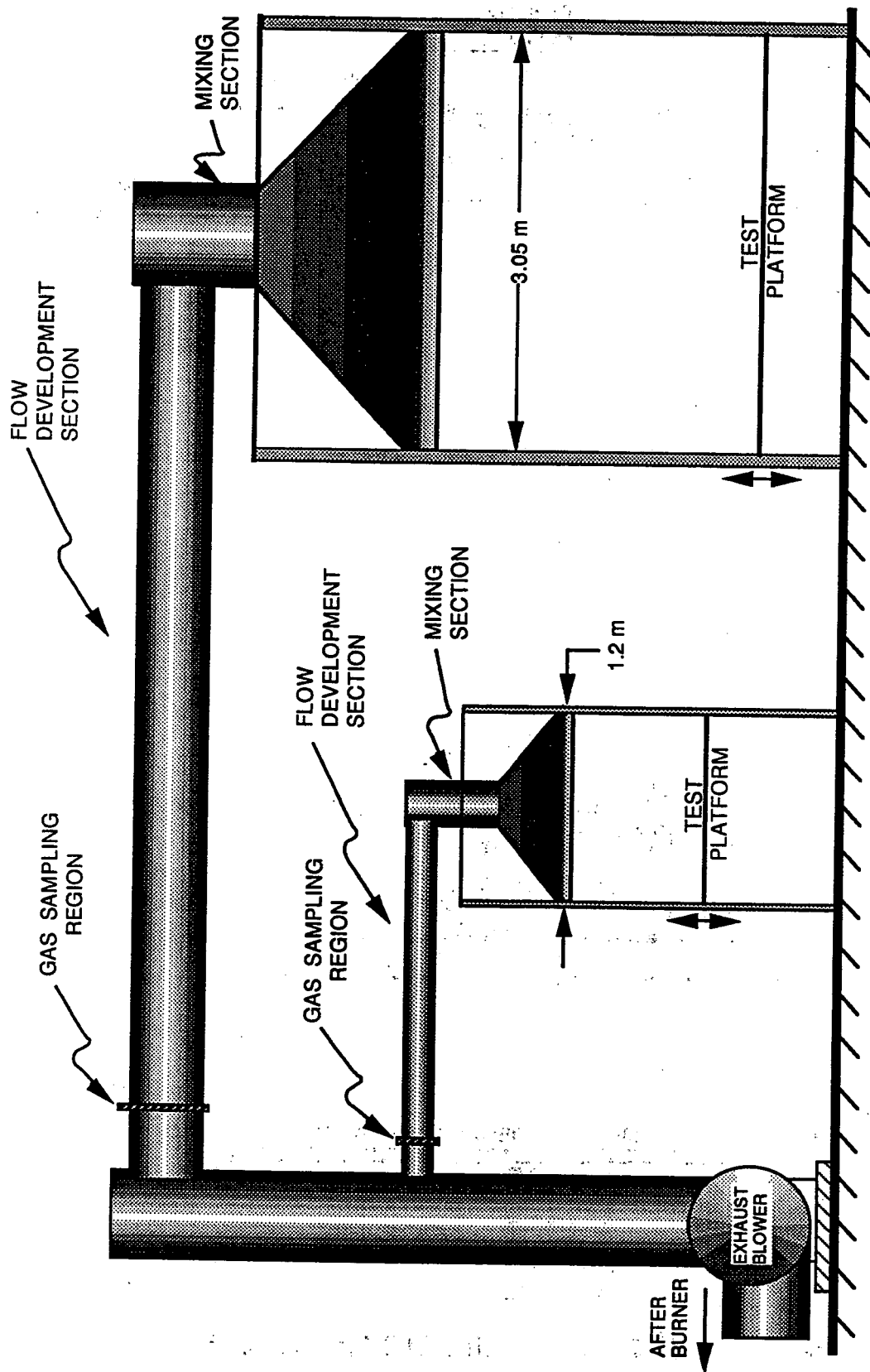
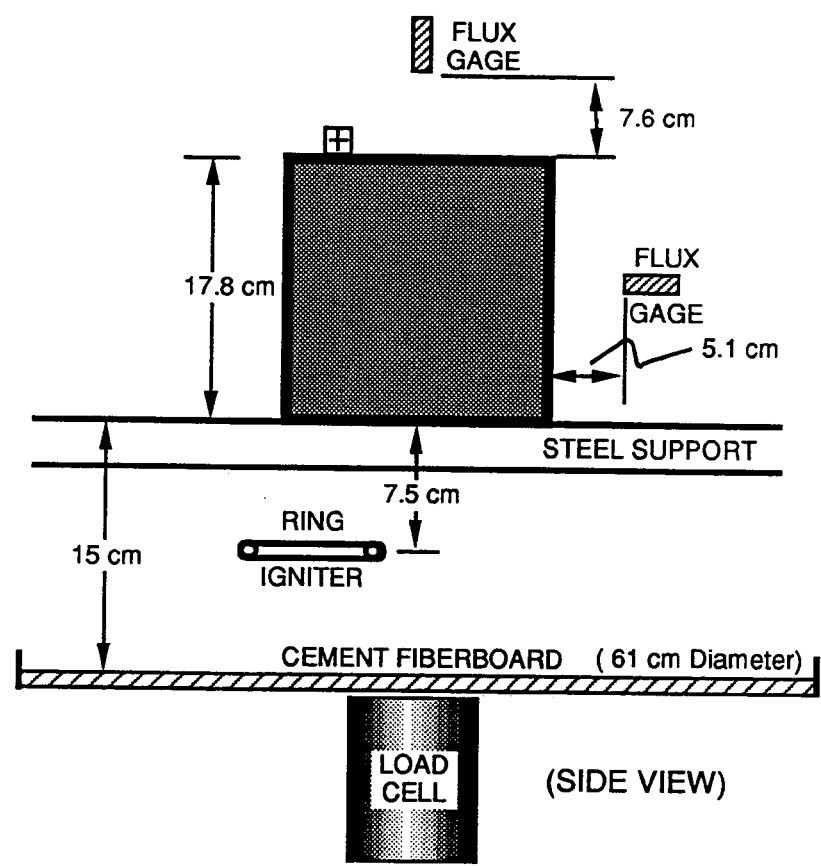
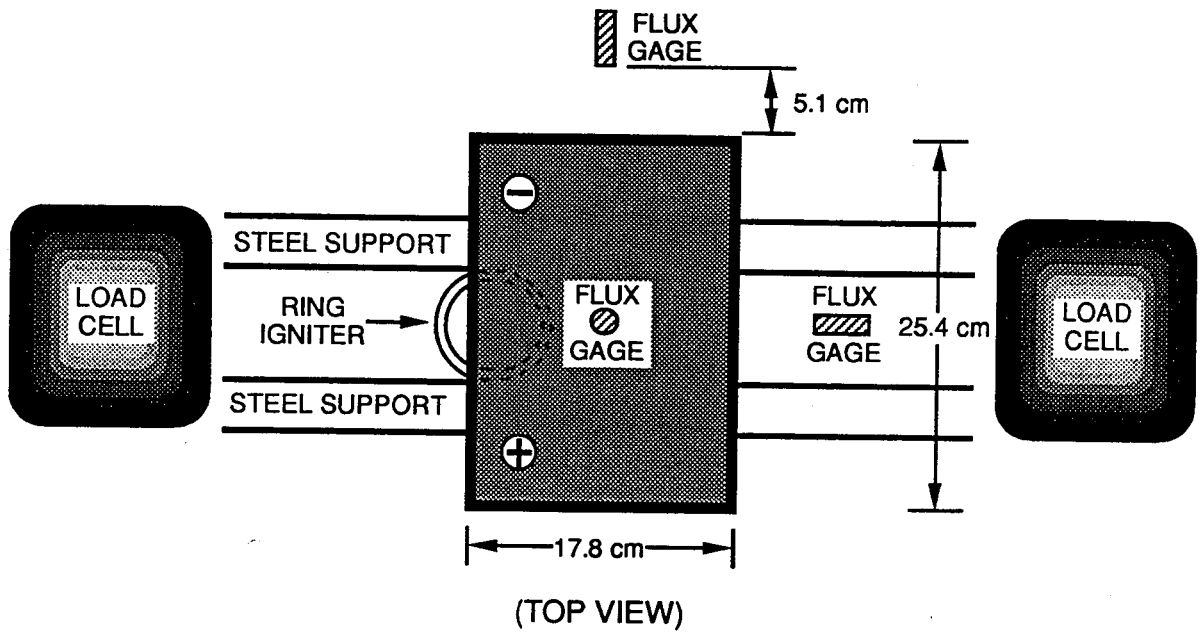

Figure 13c. Side view schematic showing parts locations in the minivan



NIST INTERMEDIATE SCALE FIRE CALORIMETRY FACILITIES

Figure 14



Test Configuration for Automobile Battery

Figure 15

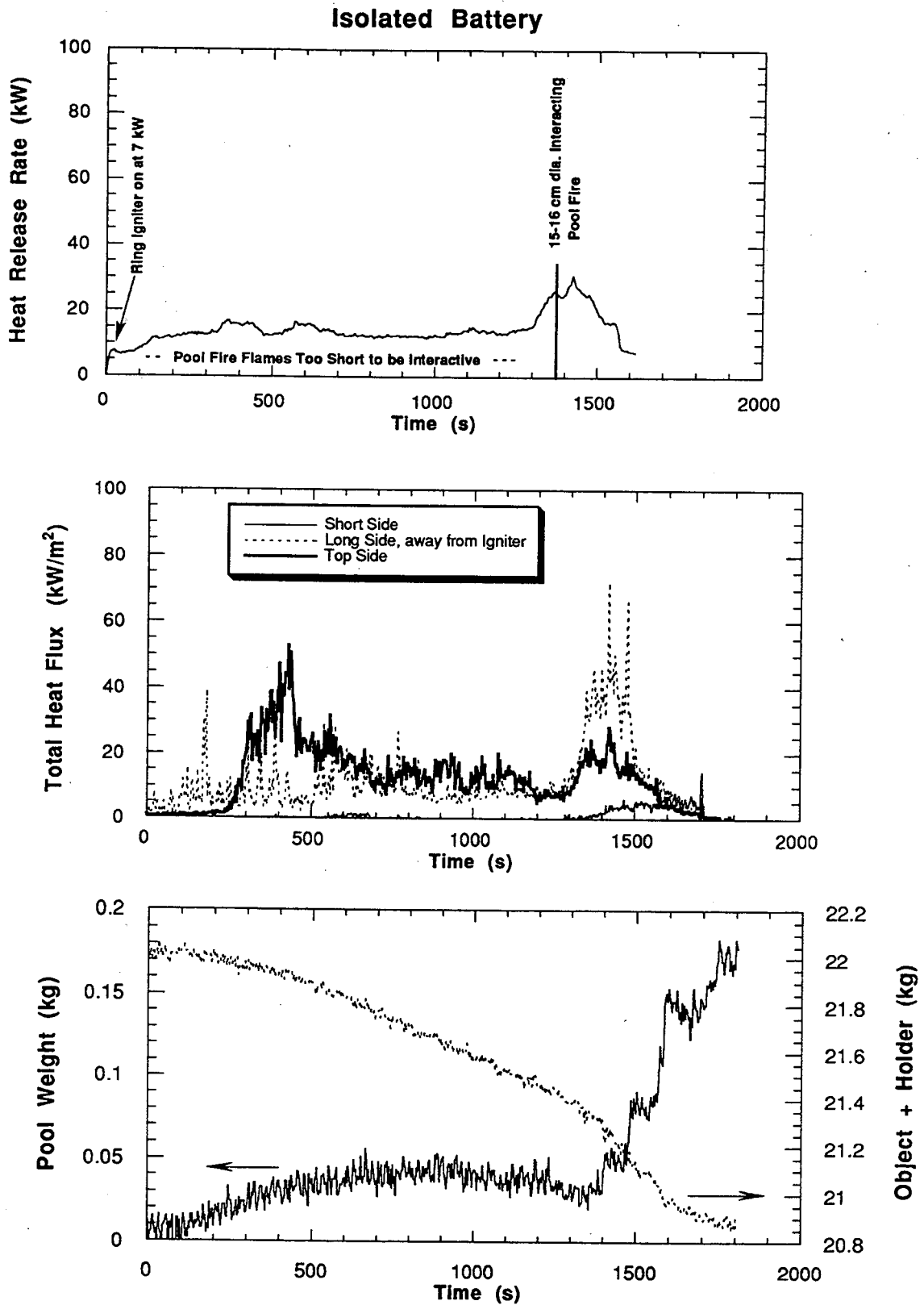

Figure 16 Test results for battery in isolation.

Battery Plus Battery Cover

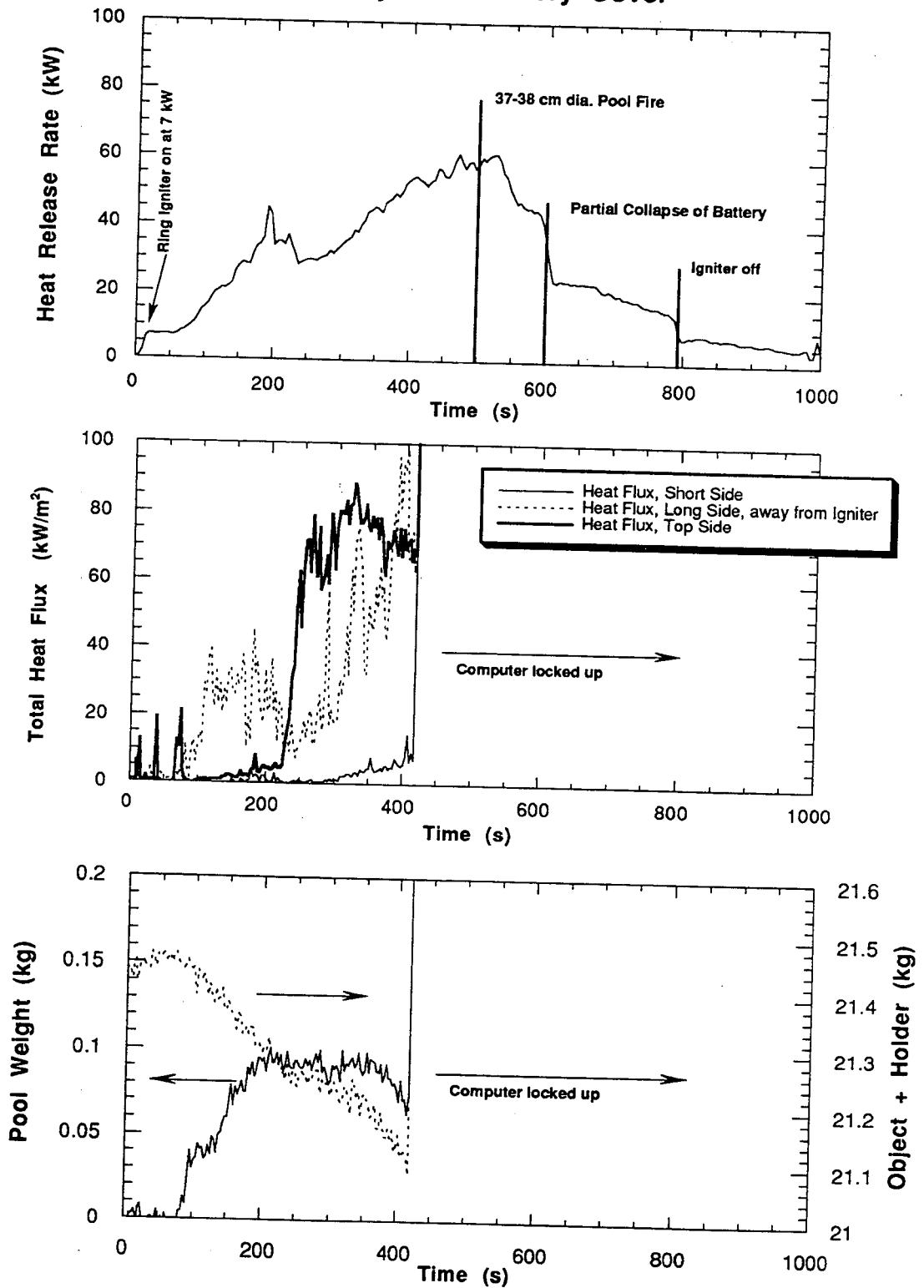

Figure 17. Test results for battery surrounded by battery cover

Battery Surrounded by Heated Box

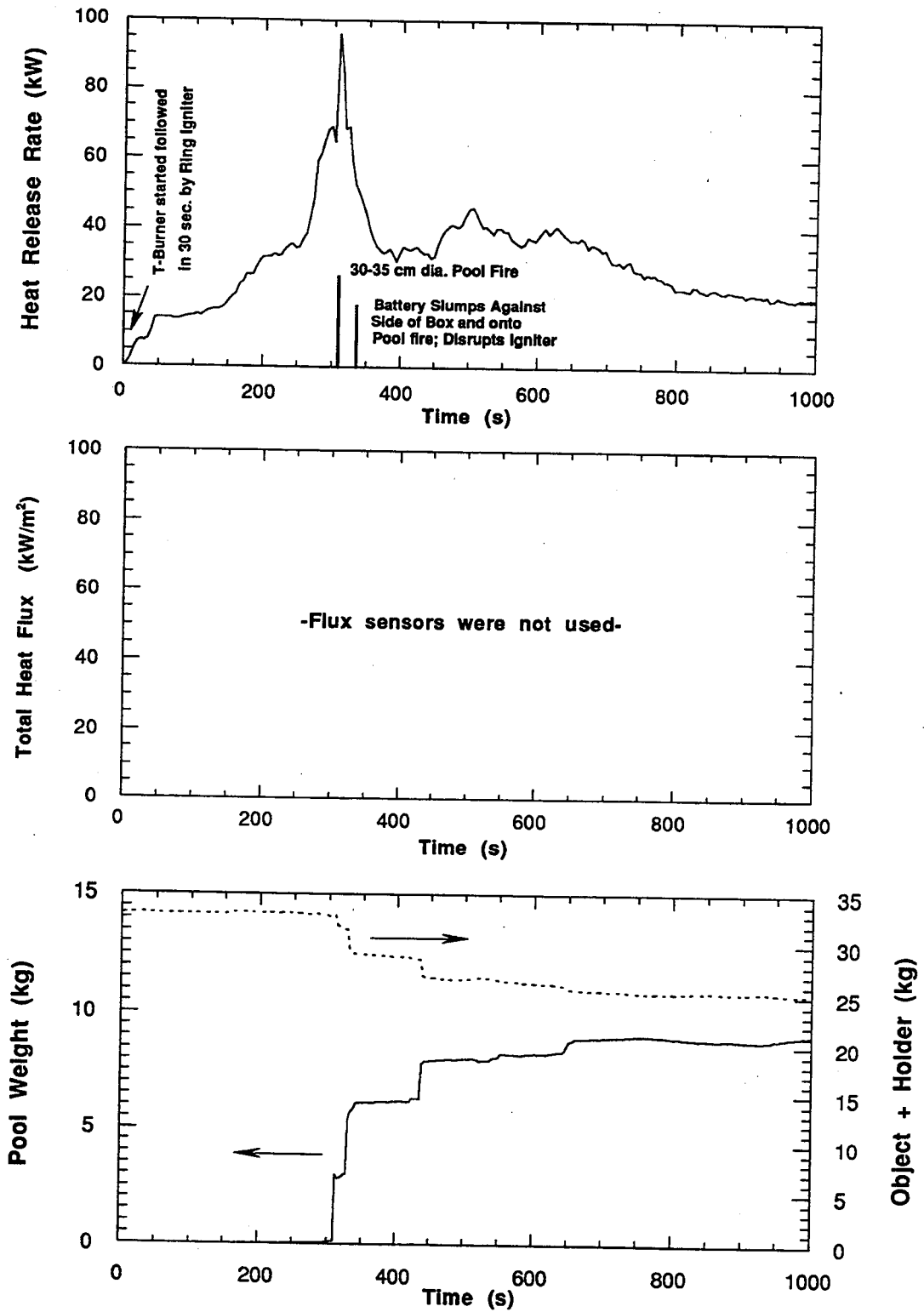

Figure 18. Test results for battery contained within heated box.

Air Intake Resonator

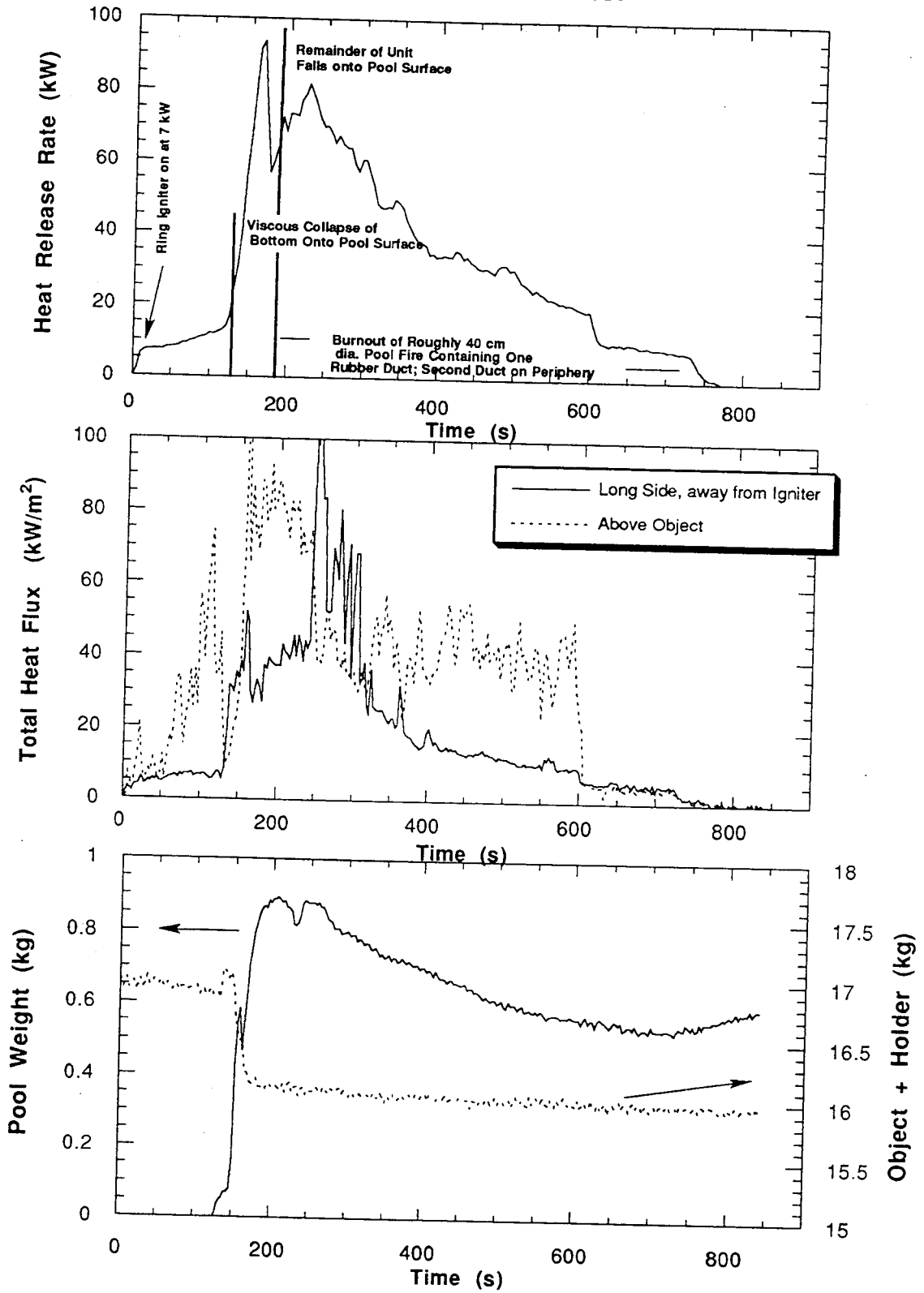

Figure 19. Burn test results for minivan air intake resonator.

Front Headlamp Assembly

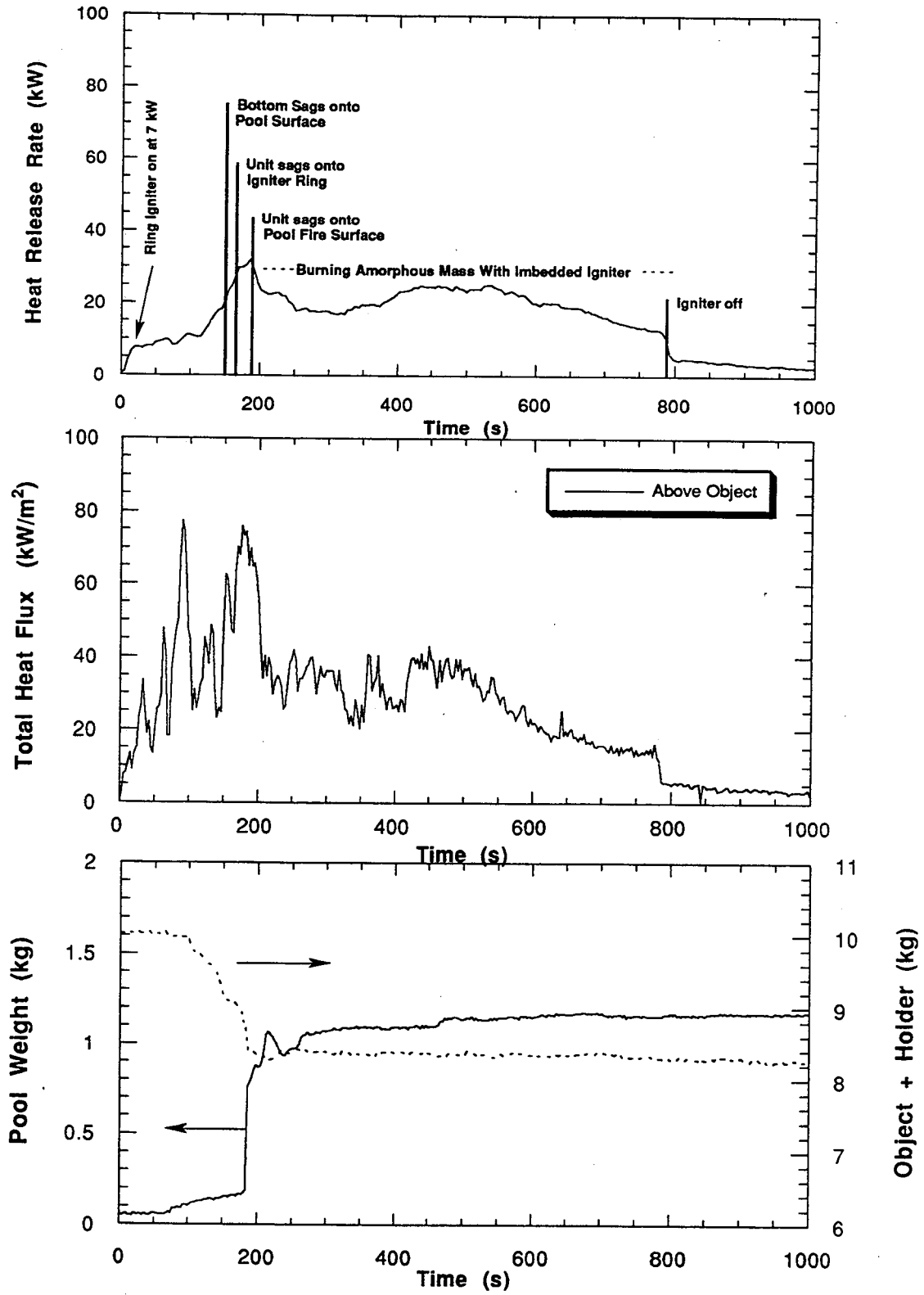

Figure 20. Burn test results for minivan front headlamp assembly.

Master Cylinder

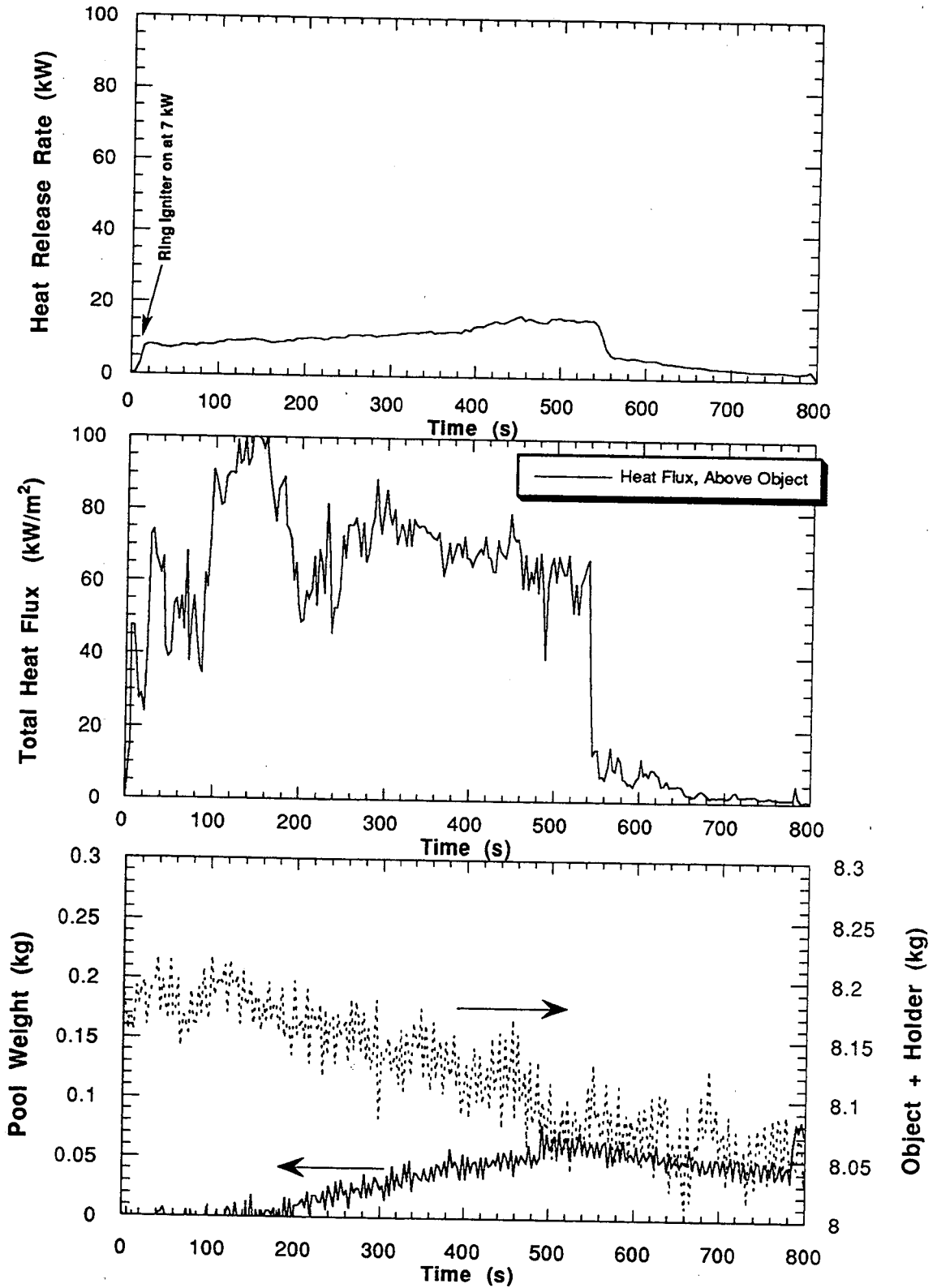

Figure 21. Burn test results for minivan brake master cylinder.

Driver's Side Half of Wiper Tray

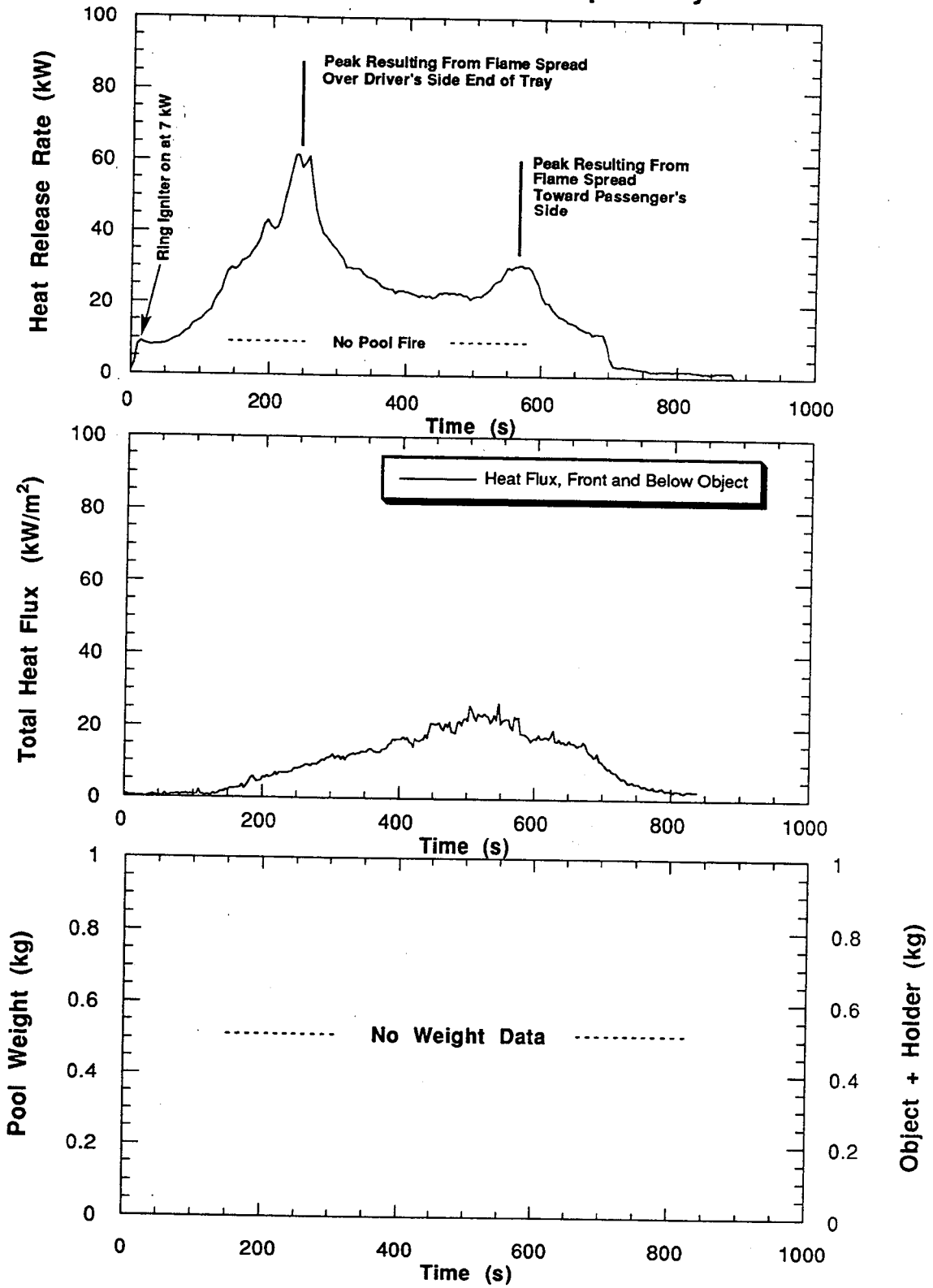

Figure 22a. Burn test results, driver's side half of minivan wiper tray.

Passenger's Side Half of Wiper Tray

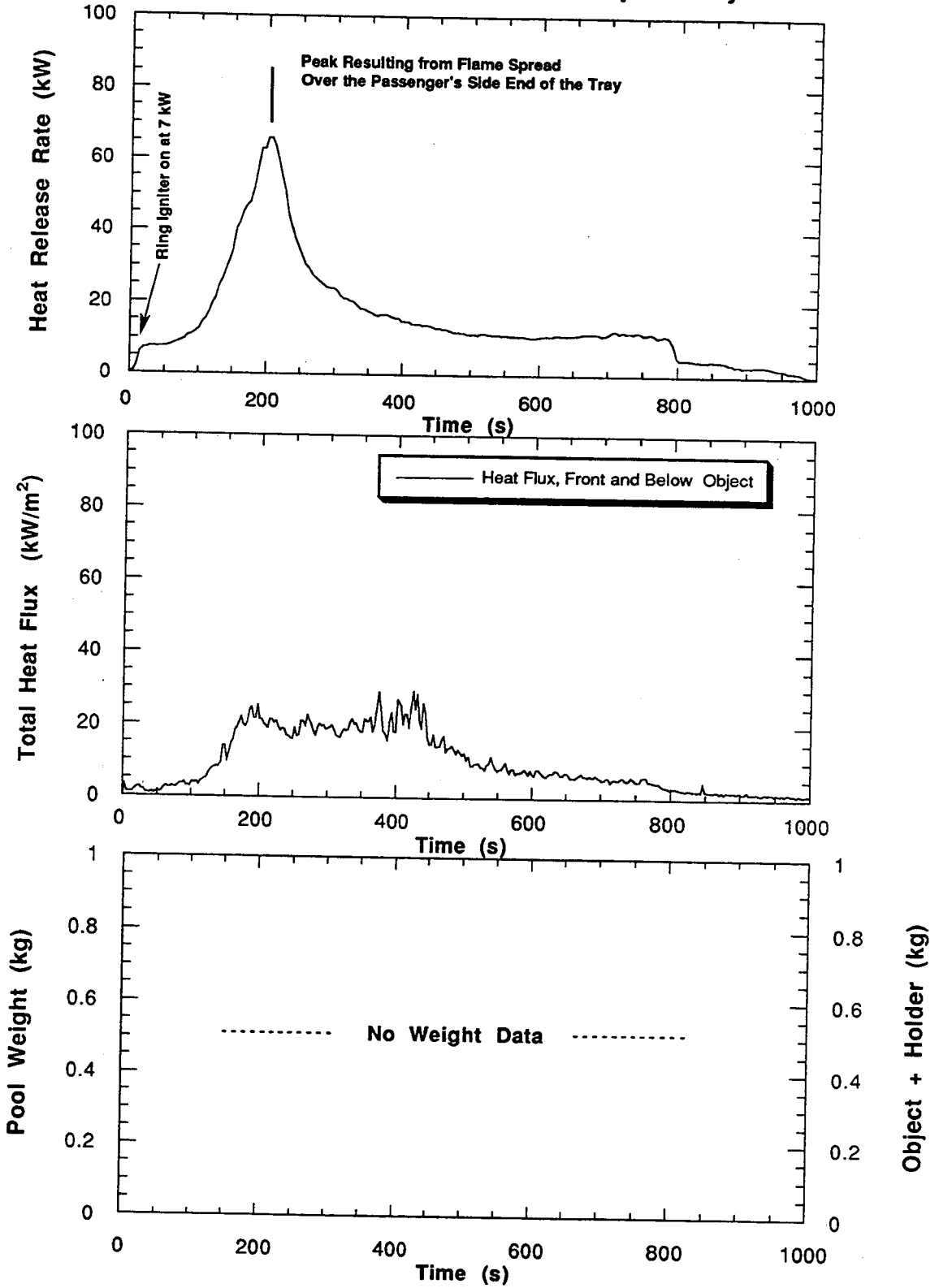

Figure 22b. Burn test results, passenger's side half of minivan wiper tray.

Passenger's Side Half of Hood Liner

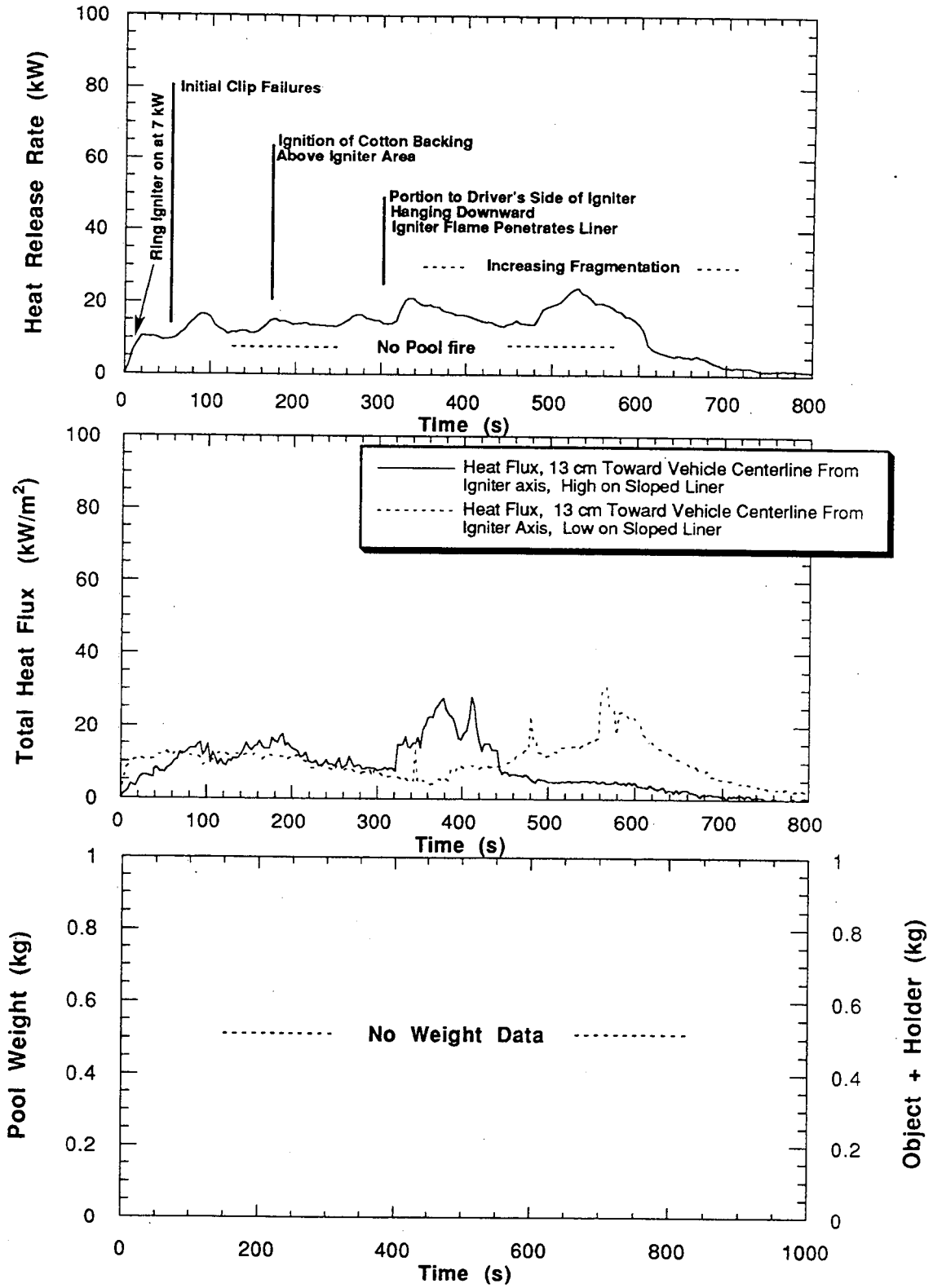

Figure 23a. Burn test results, passenger's side half of minivan hood liner.

Driver's Side Half of Hood Liner

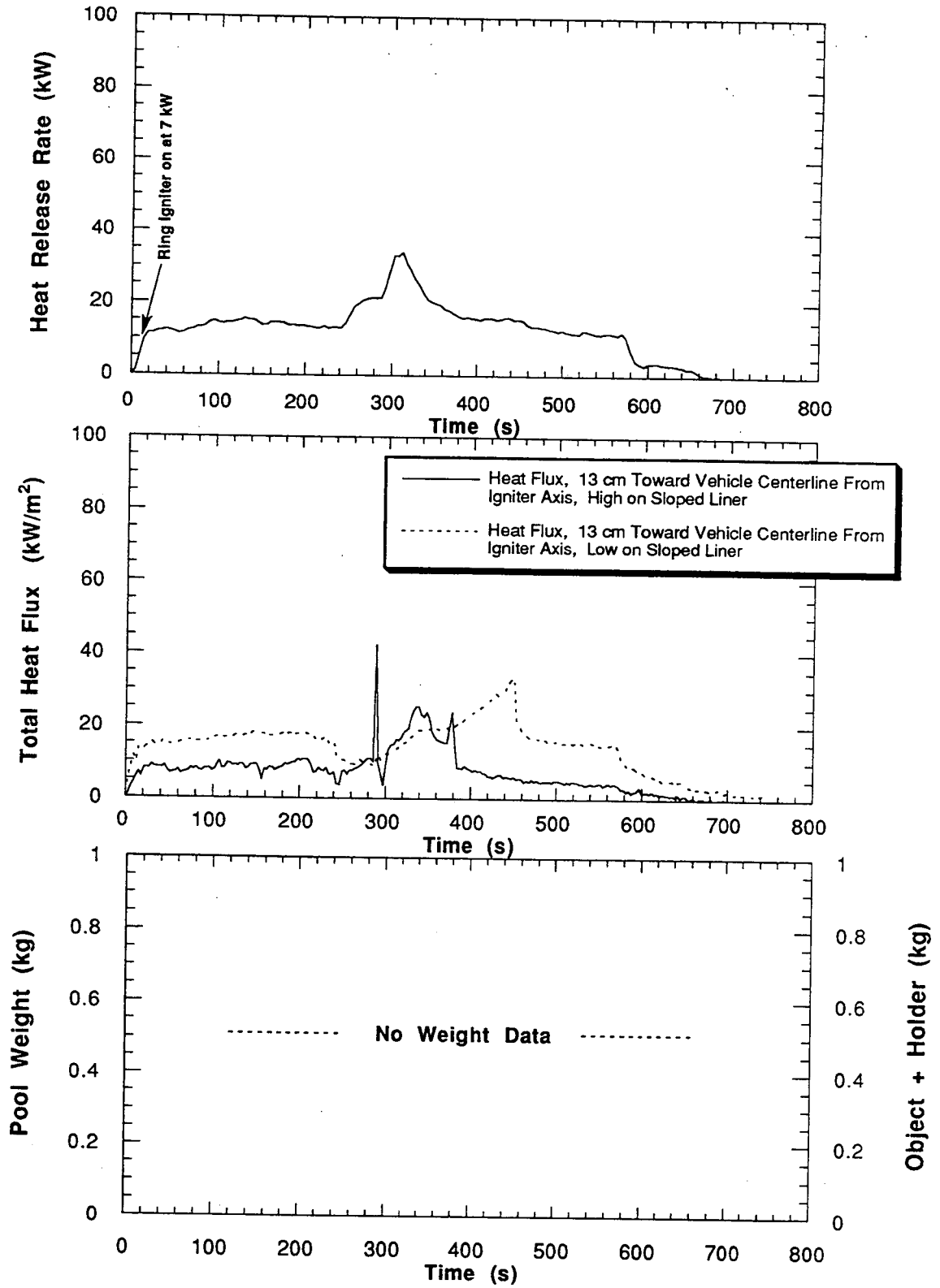

Figure 23b. Burn test results, driver's side half of minivan hood liner.

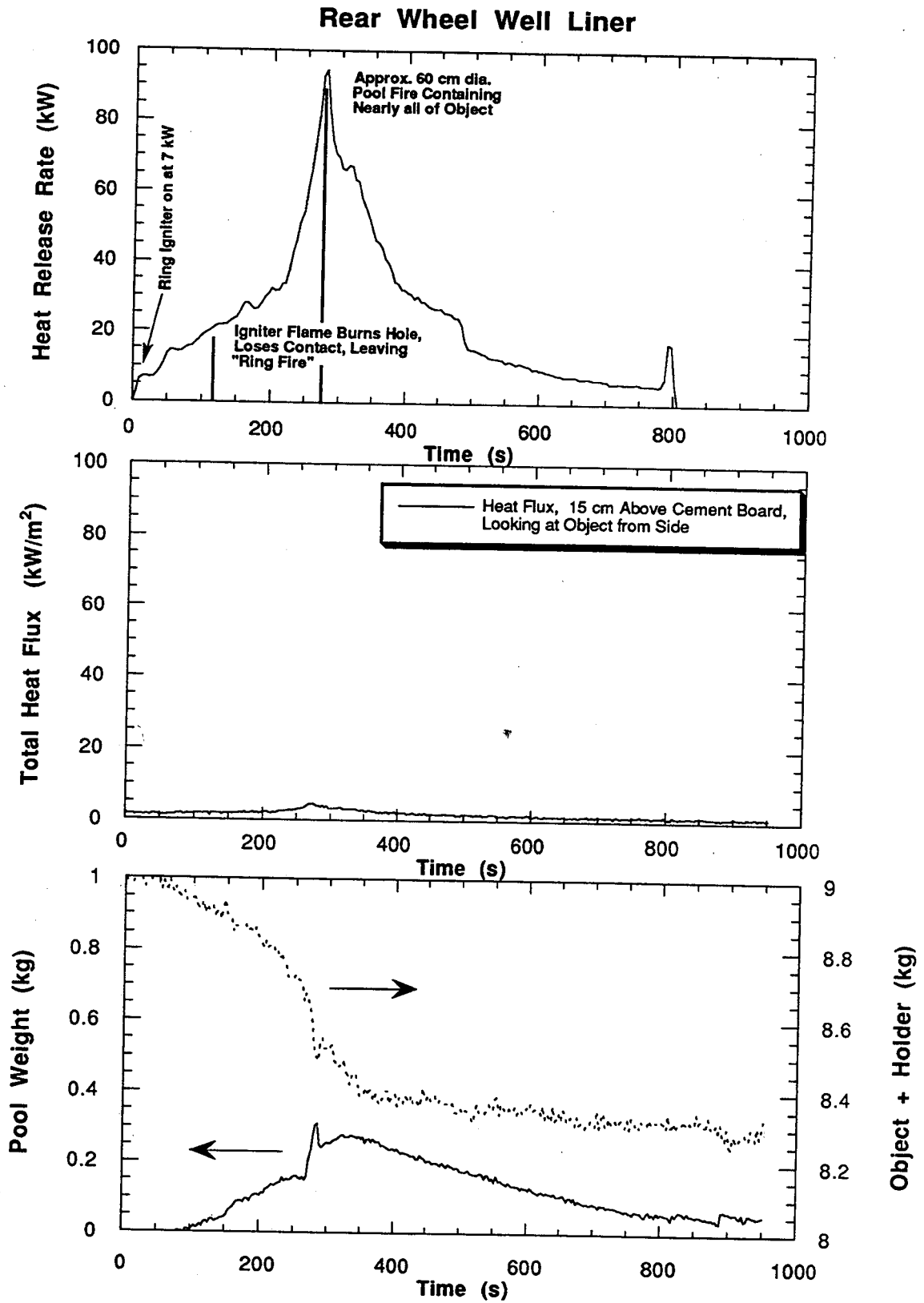

Figure 24. Burn test results, minivan rear wheel well liner.

Fuel Tank (Empty)

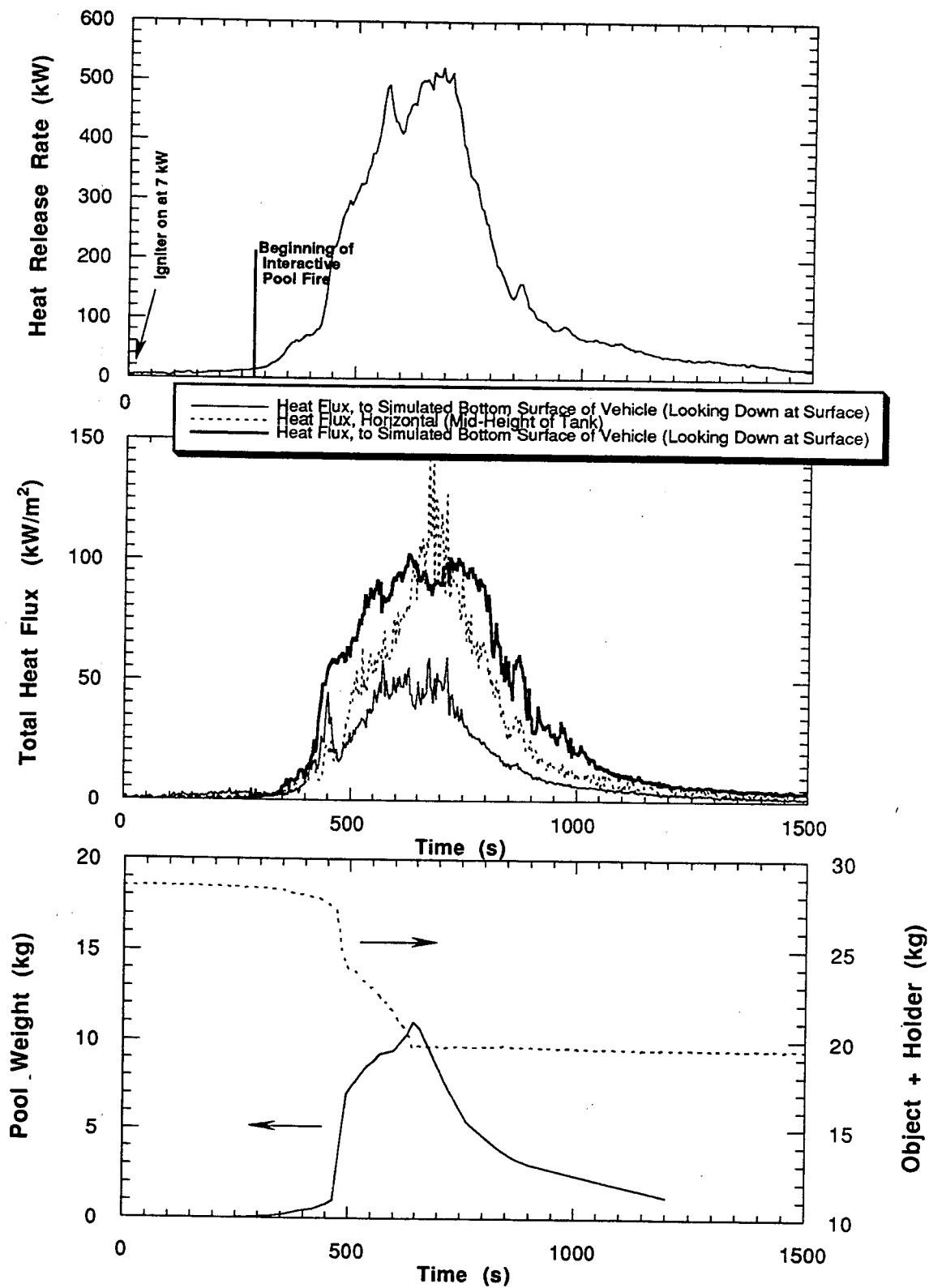

Figure 25. Burn test results, empty minivan fuel tank.

Instrument Panel

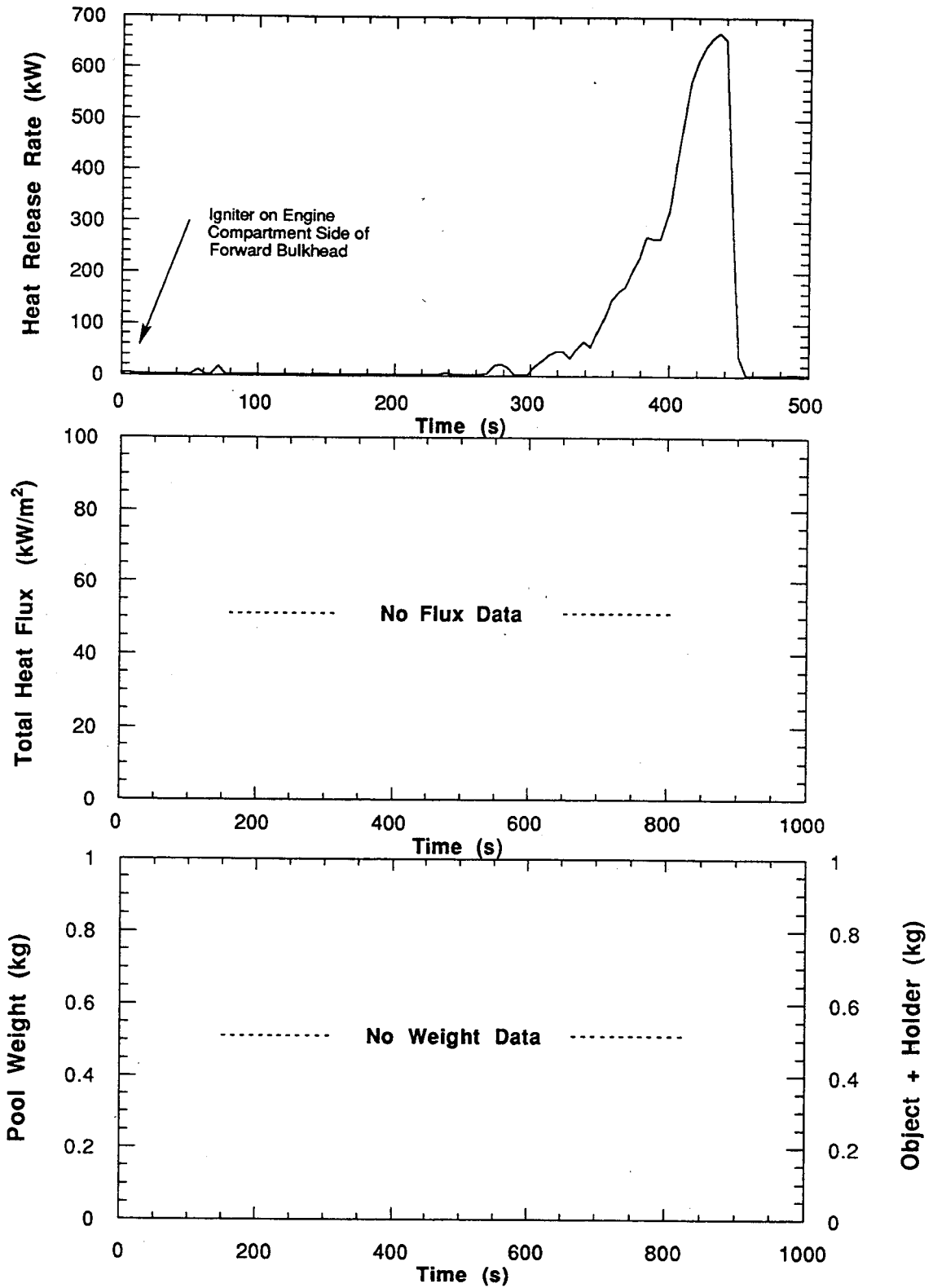

Figure 26. Burn test results for minivan instrument panel assembly in response to flames on outside of bulkhead, at heater and AC feed through points.

Seat (Single Passenger, Front)

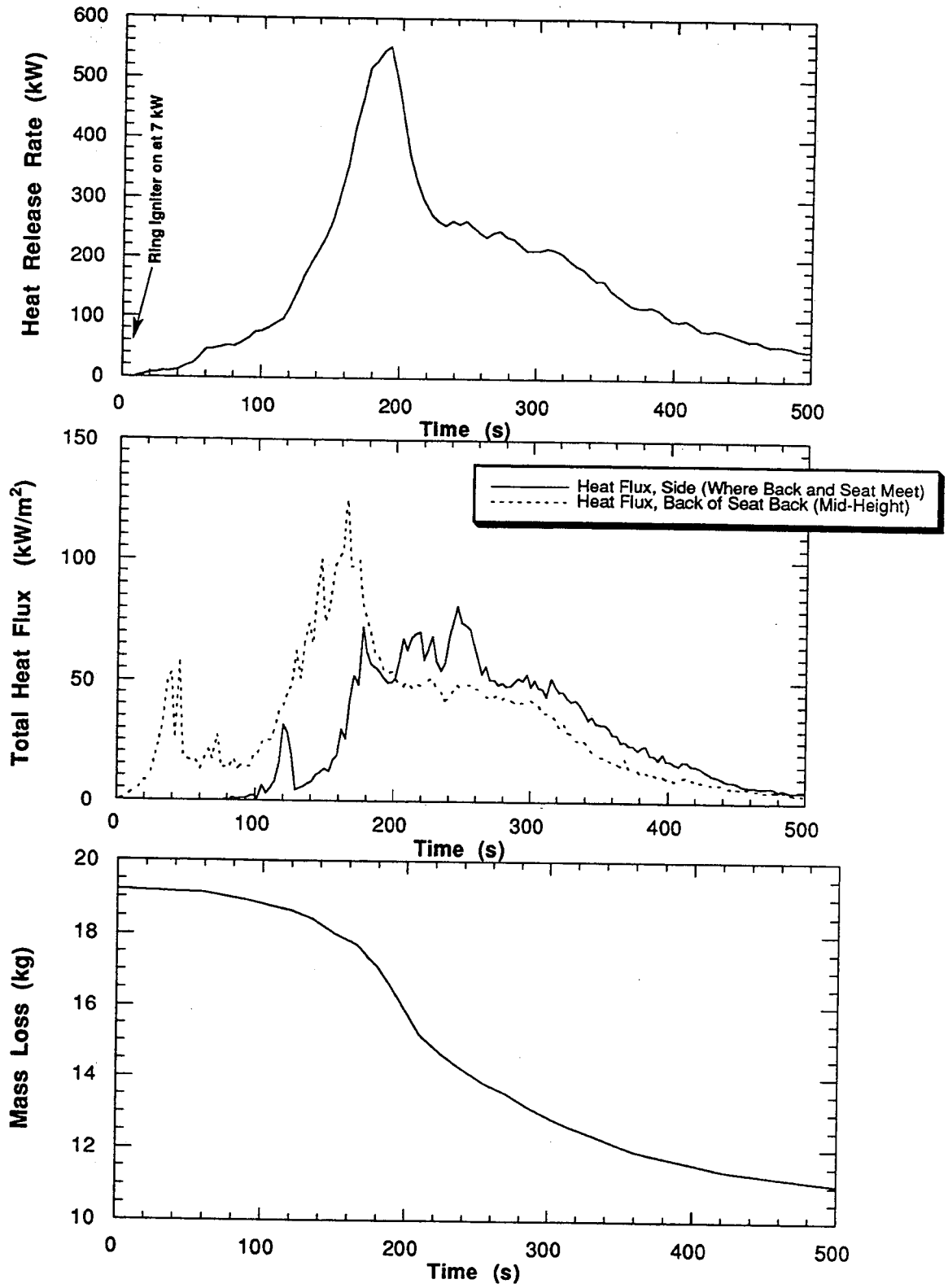

Figure 27. Burn test results for minivan front passengers seat.

Head Liner (Rear Half)

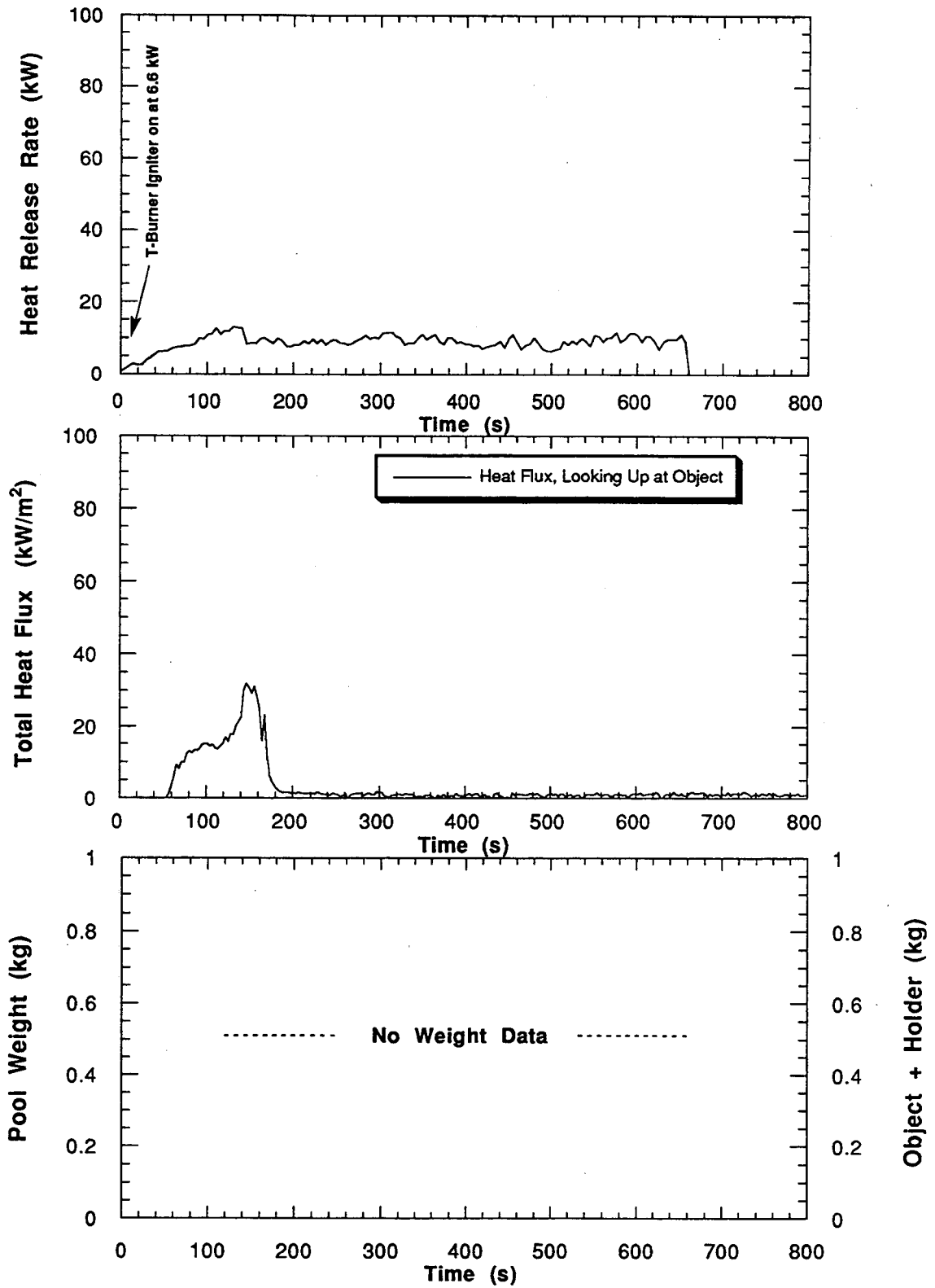

Figure 28a. Burn test results for rear half of minivan passenger compartment head liner.

Head Liner (Front Half)

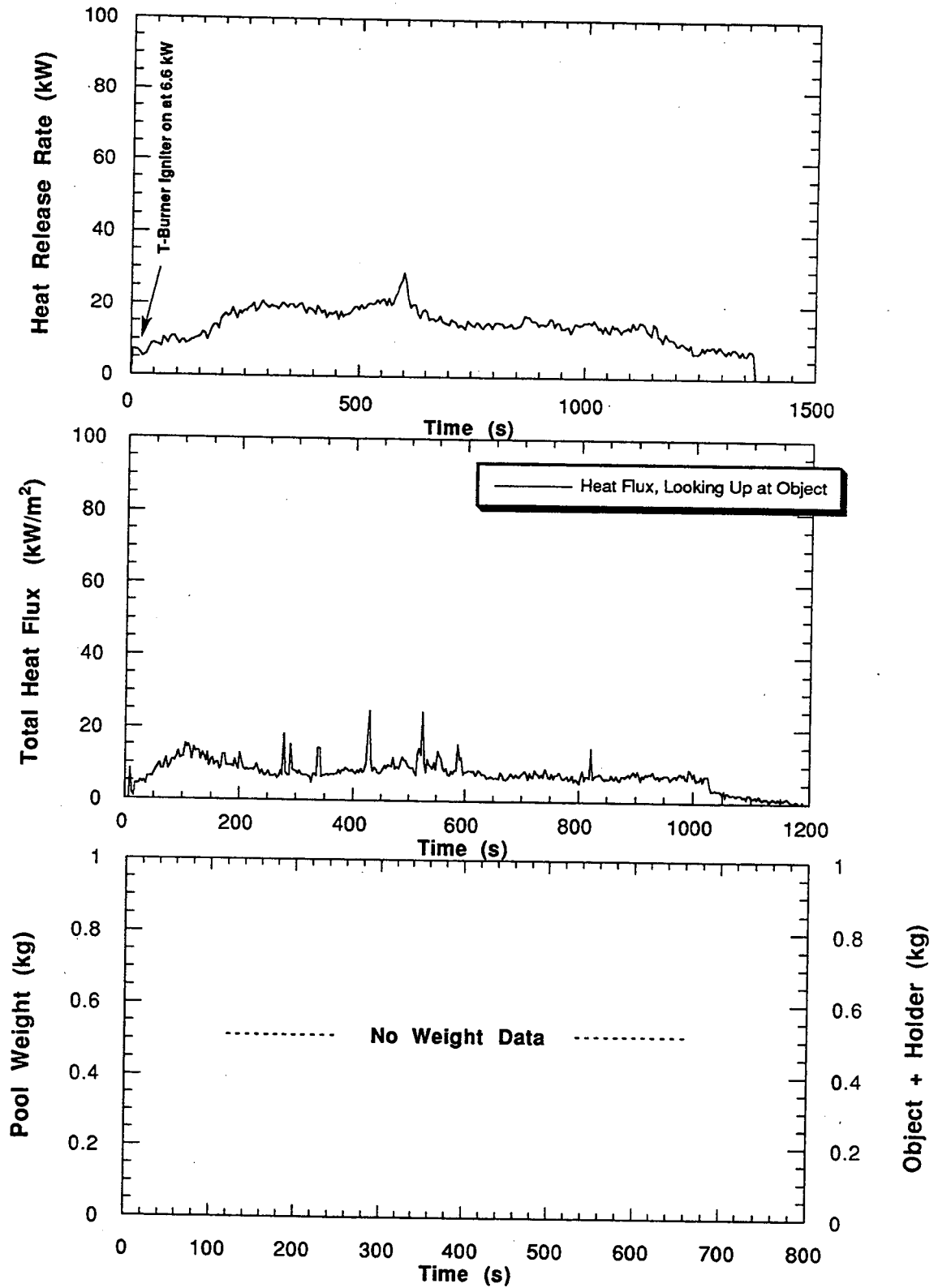

Figure 28b. Burn test results for front half of minivan passenger compartment head liner.

Peak Heat Release Rate
(Igniter Contribution Subtracted)
Versus
Mass of Polymers in Part

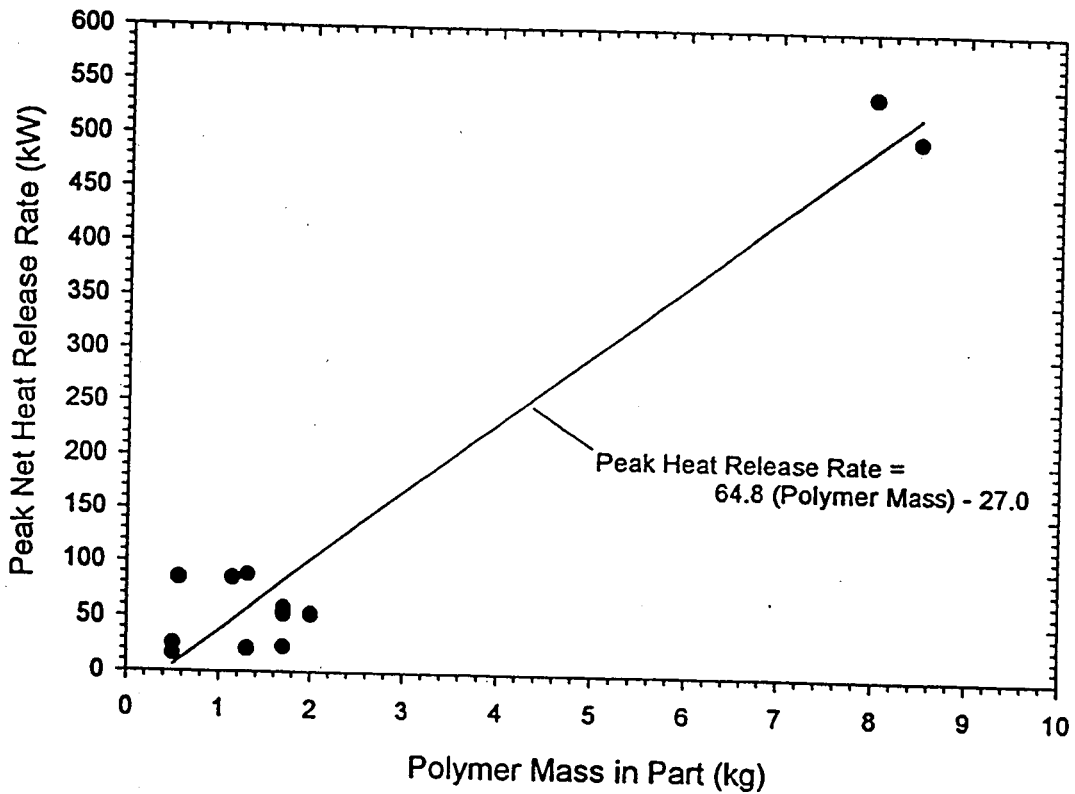

Figure 29a. Peak net heat release rate of various vehicle components versus polymer mass in component.

Small Parts Only
Peak Net Heat Release Rate
Versus
Polymer Mass in Part

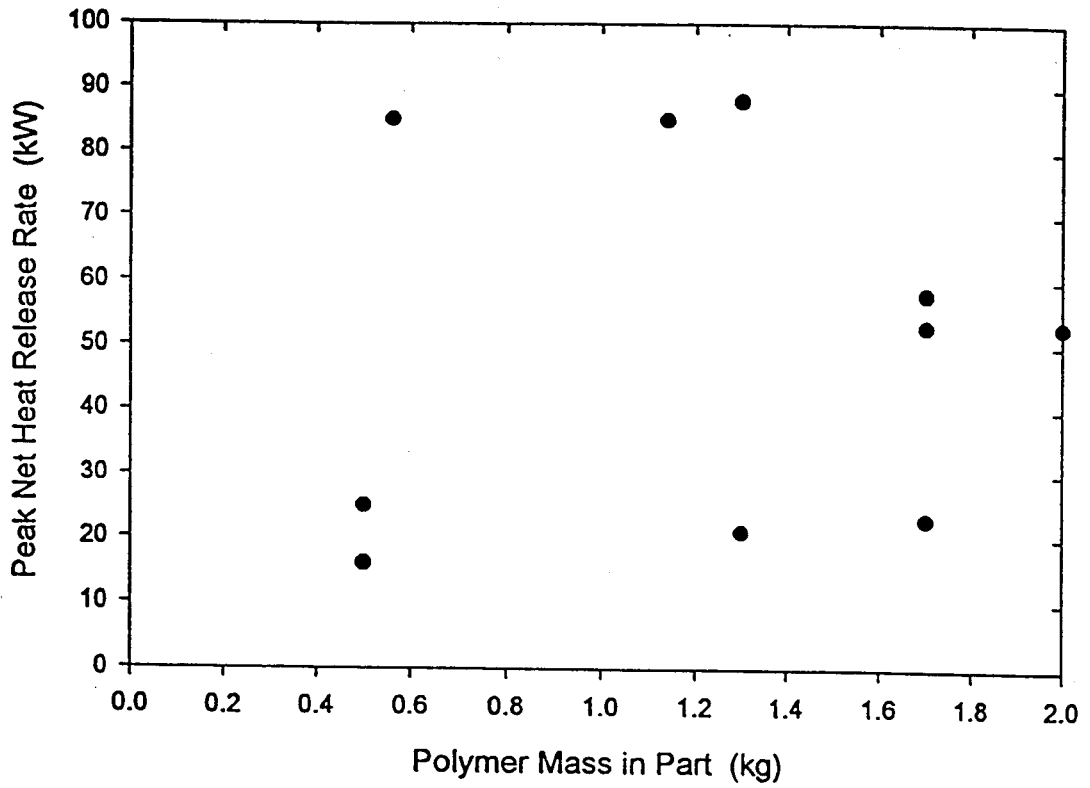

Figure 29b. Peak net heat release rate vs polymer mass for subset of small parts.